



SYNERGY3D

RESIDENTIAL

R-410A Refrigerant
Dual Capacity: 3-6 Ton



Submittal Data
English Language/IP Units
SD1300YS 07/17

Contractor: _____ P.O.: _____

Engineer: _____

Project Name: _____ Unit Tag: _____

Synergy3D Residential Series 3-6 Ton 60Hz



Model Nomenclature

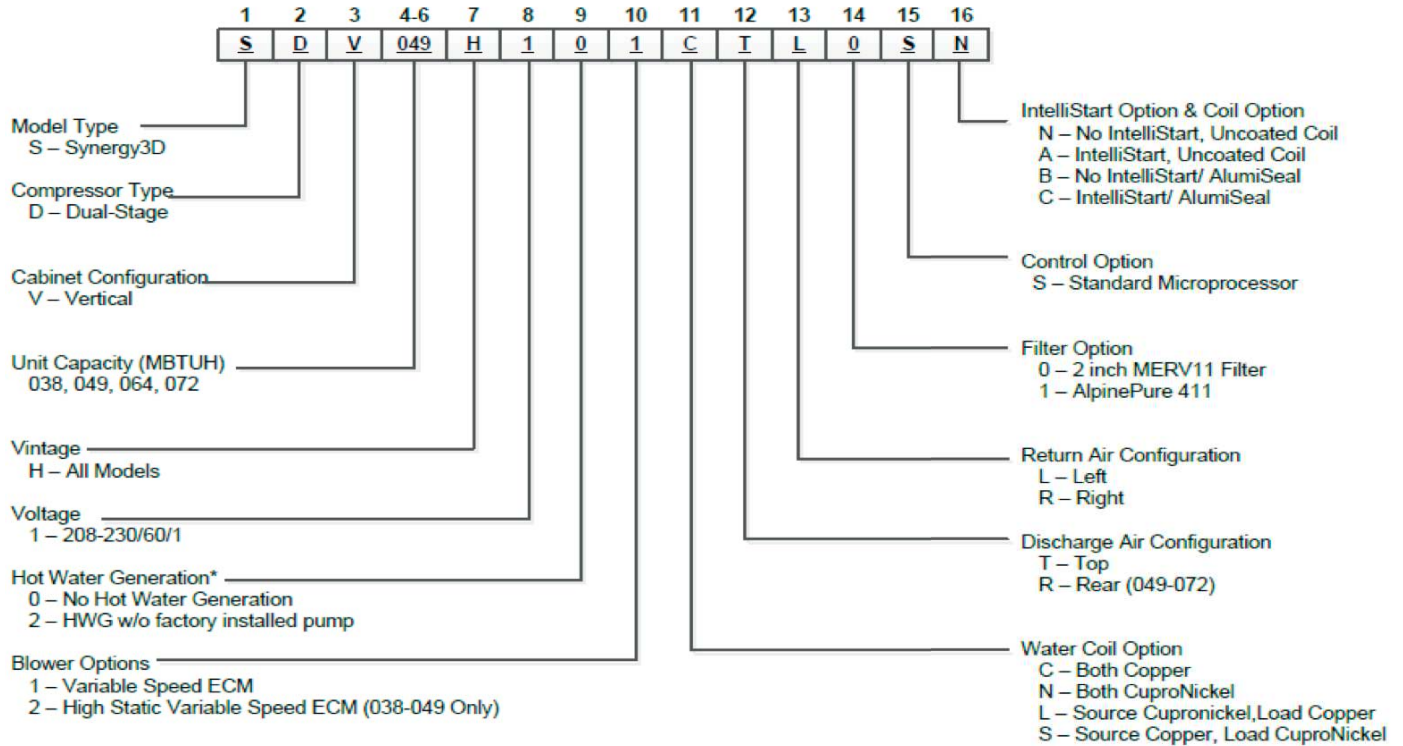

Notes:

*The factory installed Hot Water option (hot water generator) does not include a factory mounted circulating pump or temperature control. Kit DPK5 (ordered separately) includes field installed circulator, hot water tank adaptor, temperature limit and installation instructions.

Rev.: 2/8/2017

Contractor: _____ P.O.: _____

Engineer: _____

Project Name: _____ Unit Tag: _____

**Synergy3D Residential Series
3-6 Ton 60Hz**



AHRI/ISO 13256-1 Performance Ratings

ECM Motor

AHRI/ASHRAE/ISO 13256-1

English (IP) Units

Model	Capacity Modulation	Flow Rate		Ground Water Heat Pump				Ground Loop Heat Pump			
				Cooling EWT 59°F		Heating EWT 50°F		Full Load 77°F Part Load 68°F		Full Load 32°F Part Load 41°F	
		gpm	cfm	Capacity Btuh	EER Btuh/W	Capacity Btuh	COP	Capacity Btuh	EER Btuh/W	Capacity Btuh	COP
038	Full	9.0	1200	38,200	23.8	33,200	4.5	36,000	18.7	27,400	3.9
	Part	8.0	1000	28,600	30.6	23,700	4.6	27,000	24.9	21,500	4.2
049	Full	12.0	1500	50,200	23.1	46,900	4.5	47,700	18.2	38,000	3.8
	Part	11.0	1300	38,400	30.6	33,900	4.7	37,500	25.7	30,300	4.2
064	Full	16.0	1800	63,900	21.0	58,600	4.5	58,300	16.2	46,600	3.8
	Part	14.0	1500	47,800	27.2	41,500	4.7	45,100	22.6	36,900	4.2
072	Full	18.0	2000	73,400	20.3	69,000	4.3	68,500	16.1	54,500	3.7
	Part	16.0	1500	56,600	25.2	51,700	4.3	53,700	21.0	46,100	4.0

Energy Star Tier 3 affectivity date January 1, 2012

1/27/2017

Cooling capacities based upon 80.6°F DB, 66.2°F WB entering air temperature

Heating capacities based upon 68°F DB, 59°F WB entering air temperature

All ratings based upon 208V operation

**ENERGY STAR
Compliance Table**

Model	Tier 3	
	Ground Water	Ground Loop
038	Yes	Yes
049	Yes	Yes
064	Yes	Yes
072	Yes	Yes

09/23/13

ENERGY STAR Rating Criteria

In order for water-source heat pumps to be ENERGY STAR rated they must meet or exceed the minimum efficiency requirements listed below.

Tier 3: 1/1/2012 - No Effective End Date Published

Water-to-Air	EER	COP
Ground Loop	17.1	3.6
Ground Water	21.1	4.1
Water-to-Water		
Ground Loop	16.1	3.1
Ground Water	20.1	3.5



WaterFurnace works continually to improve its products. As a result, the design and specifications of each product at the time of order may be changed without notice. Please contact WaterFurnace at 1-888-929-2837 for latest design and specifications. Purchaser's approval of this data set signifies that the equipment is acceptable under the provisions of the job specification. Statements and other information contained herein are not express warranties and do not form the basis of any bargain between the parties, but are merely WaterFurnace's opinion or commendation of its products. The latest version of this document is available at www.waterfurnace.com.

Contractor: _____ P.O.: _____

Engineer: _____

Project Name: _____ Unit Tag: _____

**Synergy3D Residential Series
3-6 Ton 60Hz**



Dimensional Data

Topflow Discharge

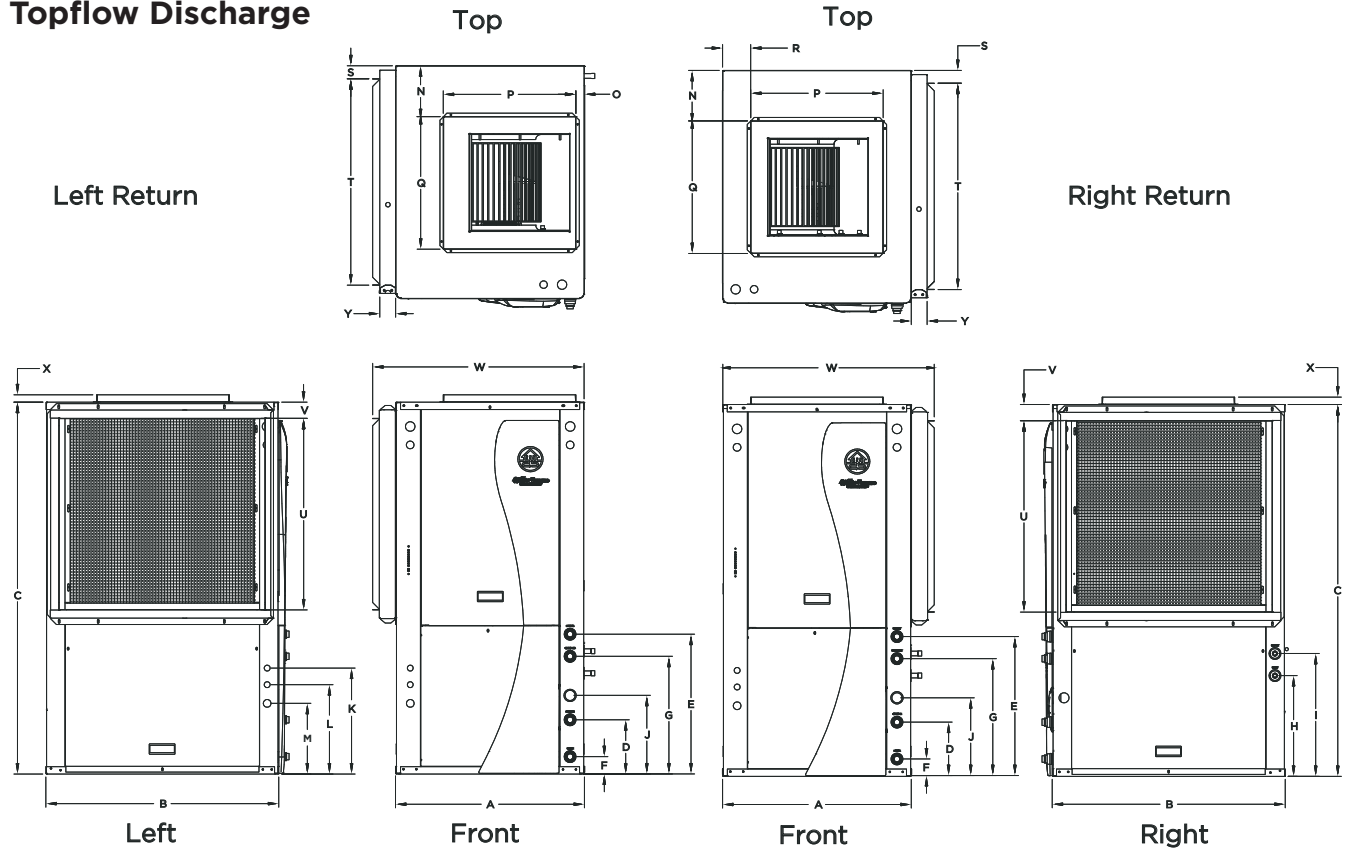

Vertical Topflow Model	Overall Cabinet			Water Connections									Electrical Connections			
	A	B	C	D	E	F	G	H	I	J	Loop Water FPT	Hydronic Water FPT	HWG Sweat (I.D.)	K	L	M
	Width	Depth	Height	Loop In	Hydronic Out	Hydronic In	Loop Out	HWG In	HWG Out	Condensate				1/2" cond	1/2" cond	3/4" cond
038	25.6 65.0	31.6 80.3	50.4 128.0	7.3 18.5	18.9 48.0	2.3 5.8	15.9 40.4	13.6 34.5	16.6 42.2	10.6 26.9	1" Swivel	1" Swivel	1/2" Female	14.4 36.6	12.1 30.7	9.6 24.4
049	25.6 65.0	31.6 80.3	54.4 138.2	7.3 18.5	18.9 48.0	2.3 5.8	15.9 40.4	15.9 40.4	18.9 48.0	10.6 26.9	1" Swivel	1" Swivel	1/2" Female	14.4 36.6	12.1 30.7	9.6 24.4
064	25.6 65.0	31.6 80.3	58.4 148.3	7.3 18.5	18.9 48.0	2.3 5.8	15.9 40.4	15.9 40.4	18.9 48.0	10.6 26.9	1" Swivel	1" Swivel	1/2" Female	14.4 36.6	12.1 30.7	9.6 24.4
072	25.6 65.0	31.6 80.3	58.4 148.3	7.3 18.5	18.9 48.0	2.3 5.8	15.9 40.4	15.9 40.4	18.9 48.0	10.6 26.9	1" Swivel	1" Swivel	1/2" Female	14.4 36.6	12.1 30.7	9.6 24.4

Discharge Connection duct flange installed (±0.10 in)				Return Connection using standard deluxe filter rack (±0.10 in)						Misc	
N	O	P Supply Width	Q Supply Depth	R	S	T Return Depth	U Return Height	V	W	X	Y
6.9	1.1	18.0	18.0	3.8	1.7	28.1	26.0	2.2	28.7	1.0	2.1
17.5	2.8	45.7	45.7	9.7	4.3	71.4	66.0	5.6	72.9	2.5	5.3
6.9	1.1	18.0	18.0	3.8	1.7	28.1	30.0	2.2	28.7	1.0	2.1
17.5	2.8	45.7	45.7	9.7	4.3	71.4	76.2	5.6	72.9	2.5	5.3
6.9	1.1	18.0	18.0	3.8	1.7	28.1	34.0	2.2	28.7	1.0	2.1
17.5	2.8	45.7	45.7	9.7	4.3	71.4	86.4	5.6	72.9	2.5	5.3
6.9	1.1	18.0	18.0	3.8	1.7	28.1	34.0	2.2	28.7	1.0	2.1
17.5	2.8	45.7	45.7	9.7	4.3	71.4	86.4	5.6	72.9	2.5	5.3

Condensate is 3/4 in. PVC female glue socket and is switchable from side to front
 Unit shipped with deluxe 2 in. (field adjustable to 1 in.) duct collar/filter rack extending from unit 3.25 in. and is suitable for duct connection.
 Discharge flange is field installed and extends 1 in. [25.4 mm] from cabinet
 Decorative molding and water connections extend 1.2 in. [30.5 mm] beyond front of cabinet.

WaterFurnace works continually to improve its products. As a result, the design and specifications of each product at the time of order may be changed without notice. Please contact WaterFurnace at 1-888-929-2837 for latest design and specifications. Purchaser's approval of this data set signifies that the equipment is acceptable under the provisions of the job specification. Statements and other information contained herein are not express warranties and do not form the basis of any bargain between the parties, but are merely WaterFurnace's opinion or commendation of its products. The latest version of this document is available at www.waterfurnace.com.

Contractor: _____ P.O.: _____
 Engineer: _____
 Project Name: _____ Unit Tag: _____

**Synergy3D Residential Series
 3-6 Ton 60Hz**



Dimensional Data cont.

Rear Discharge

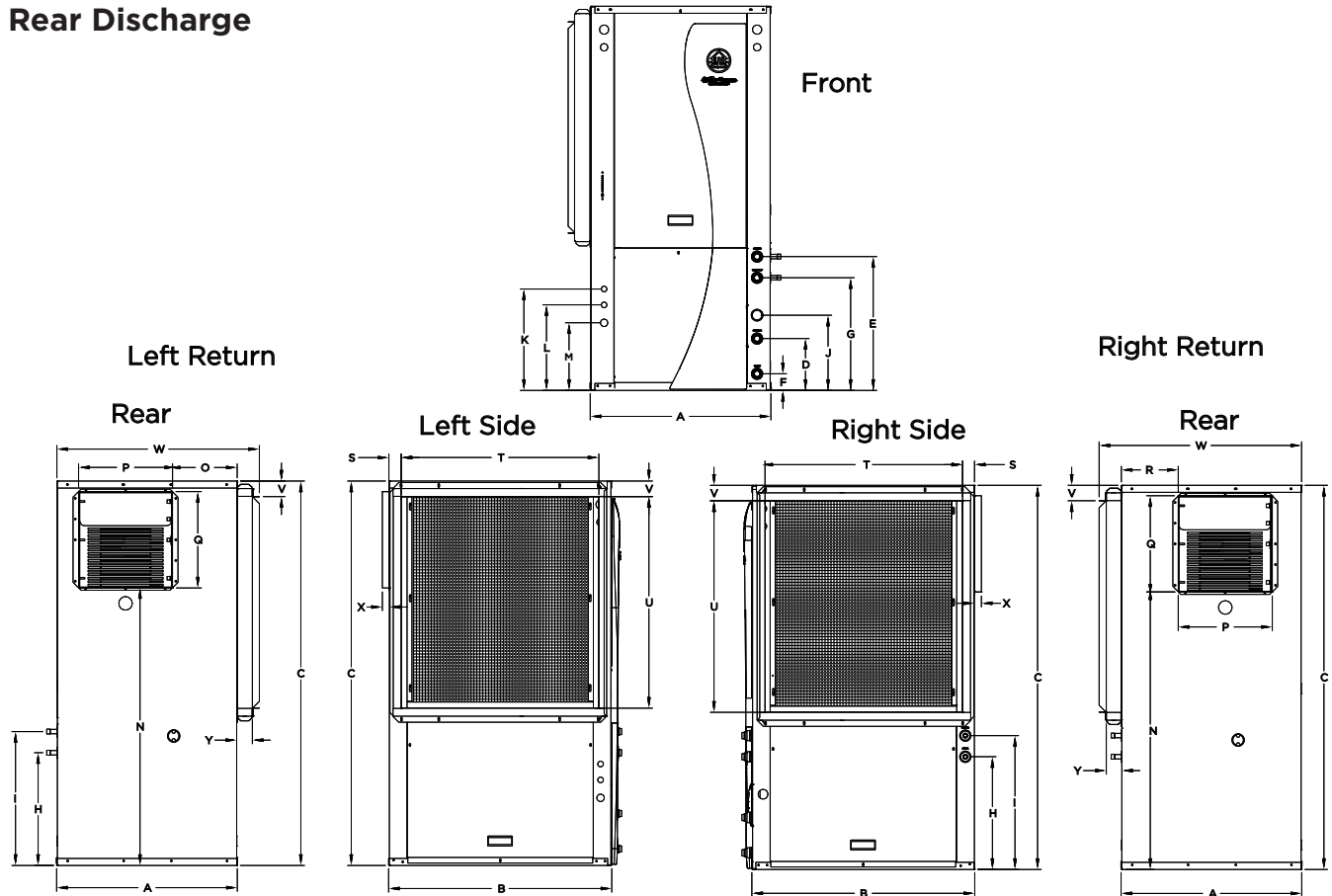

Vertical Backflow Model	Overall Cabinet			Water Connections										Electrical Connections			
	A	B	C	D	E	F	G	H	I	J	Loop Water FPT	Hydronic Water FPT	HWG Sweat (I.D.)	K	L	M	
	Width	Depth	Height	Loop In	Hydronic Out	Hydronic In	Loop Out	HWG In	HWG Out	Condensate				1/2" cond	1/2" cond	3/4" cond	
049	in. cm.	25.6 65.0	31.6 80.3	54.4 138.2	7.3 18.5	18.9 48.0	2.3 5.8	15.9 40.4	15.9 40.4	18.9 48.0	10.6 26.9	1" Swivel	1" Swivel	1/2" Female	14.4 36.6	12.1 30.7	9.6 24.4
064	in. cm.	25.6 65.0	31.6 80.3	58.4 148.3	7.3 18.5	18.9 48.0	2.3 5.8	15.9 40.4	15.9 40.4	18.9 48.0	10.6 26.9	1" Swivel	1" Swivel	1/2" Female	14.4 36.6	12.1 30.7	9.6 24.4
072	in. cm.	25.6 65.0	31.6 80.3	58.4 148.3	7.3 18.5	18.9 48.0	2.3 5.8	15.9 40.4	15.9 40.4	18.9 48.0	10.6 26.9	1" Swivel	1" Swivel	1/2" Female	14.4 36.6	12.1 30.7	9.6 24.4

Discharge Connection duct flange installed (±0.10 in)				Return Connection using std deluxe filter rack (±0.10 in)						Misc	
N	O	P Supply Width	Q Supply Depth	R	S	T Return Depth	U Return Height	V	W	X	Y
39.4 100.1	9.1 23.1	13.3 33.8	13.6 34.5	8.1 20.6	1.7 4.3	28.1 71.4	30.0 76.2	2.2 5.6	28.7 72.9	1.0 2.5	2.1 5.3
43.4 110.2	9.1 23.1	13.3 33.8	13.6 34.5	8.1 20.6	1.7 4.3	28.1 71.4	34.0 86.4	2.2 5.6	28.7 72.9	1.0 2.5	2.1 5.3
43.4 110.2	9.1 23.1	13.3 33.8	13.6 34.5	8.1 20.6	1.7 4.3	28.1 71.4	34.0 86.4	2.2 5.6	28.7 72.9	1.0 2.5	2.1 5.3

10/16/2013

Condensate is 3/4 in. PVC female glue socket and is switchable from side to front
 Unit shipped with deluxe 2 in. (field adjustable to 1 in.) duct collar/filter rack extending from unit 3.25 in. and is suitable for duct connection.
 Discharge flange is field installed and extends 1 in. [25.4 mm] from cabinet
 Decorative molding and water connections extend 1.2 in. [30.5 mm] beyond front of cabinet.

WaterFurnace works continually to improve its products. As a result, the design and specifications of each product at the time of order may be changed without notice. Please contact WaterFurnace at 1-888-929-2837 for latest design and specifications. Purchaser's approval of this data set signifies that the equipment is acceptable under the provisions of the job specification. Statements and other information contained herein are not express warranties and do not form the basis of any bargain between the parties, but are merely WaterFurnace's opinion or commendation of its products. The latest version of this document is available at www.waterfurnace.com.

Contractor: _____ P.O.: _____

Engineer: _____

Project Name: _____ Unit Tag: _____

**Synergy3D Residential Series
3-6 Ton 60Hz**



Physical Data

Model	038	049	064	072
Compressor (1 each)	Copeland Scroll			
Factory Charge R410a, oz [kg]	82 [2.32]	102 [2.89]	120 [3.40]	120 [3.40]
ECM Fan Motor & Blower				
Fan Motor Type/Speeds	Variable Speed ECM			
Fan Motor- hp [W]	1/2 [373]	1/2 [373]	1 [746]	1 [746]
Blower Wheel Size (Dia x W), in. [mm]	11 x 10 [279 x 254]	11 x 10 [279 x 254]	11 x 10 [279 x 254]	11 x 10 [279 x 254]
Coax and Water Piping				
Loop Water Connections Size - Swivel - in [mm]	1" [25.4]	1" [25.4]	1" [25.4]	1" [25.4]
Hydronic Water Connections Size - Swivel - in [mm]	1" [25.4]	1" [25.4]	1" [25.4]	1" [25.4]
HWG Connection Size - Female Sweat (I.D.) - in [mm]	1/2" [12.7]	1/2" [12.7]	1/2" [12.7]	1/2" [12.7]
Coax & Piping Water Volume - gal [l]	1.3 [4.9]	1.6 [6.1]	1.6 [6.1]	1.6 [6.1]
Vertical				
Air Coil Dimensions (H x W), in. [mm]	28 x 25 [711 x 635]	32 x 25 [813 x 635]	36 x 25 [914 x 635]	36 x 25 [914 x 635]
Air Coil Total Face Area, ft ² [m ²]	4.9 [0.451]	5.6 [0.570]	6.3 [0.641]	6.3 [0.641]
Air Coil Tube Size, in [mm]	3/8 [9.5]	3/8 [9.5]	3/8 [9.5]	3/8 [9.5]
Air Coil Number of rows	3	3	4	4
Filter Standard - 2" [51mm] Pleated MERV11 Disposable, in [mm]	28 x 30 [712 x 762]	32 x 30 [813 x 762]	36 x 30 [914 x 762]	36 x 30 [914 x 762]
Weight - Operating, lb [kg]	425	530	540	540
Weight - Packaged, lb [kg]	445	550	560	560

3/15/17

WaterFurnace works continually to improve its products. As a result, the design and specifications of each product at the time of order may be changed without notice. Please contact WaterFurnace at 1-888-929-2837 for latest design and specifications. Purchaser's approval of this data set signifies that the equipment is acceptable under the provisions of the job specification. Statements and other information contained herein are not express warranties and do not form the basis of any bargain between the parties, but are merely WaterFurnace's opinion or commendation of its products. The latest version of this document is available at www.waterfurnace.com.

Contractor: _____ P.O.: _____

Engineer: _____

Project Name: _____ Unit Tag: _____

**Synergy3D Residential Series
3-6 Ton 60Hz**



Auxiliary Heat

Auxiliary Heat Electrical Data

Model	Supply Circuit	Heater Amps		Min Circuit Amp		Max Fuse (USA)		Max Fuse (CAN)		Max CKT BRK	
		208V	240V	208V	240V	208V	240V	208V	240V	208V	240V
EAL(H)10A	Single	34.7	40	53.3	60	60	60	60	60	60	60
EAL(H)15A	Single	52.0	60	75	85	80	90	80	90	70	100
	L1/L2	34.7	40	53.3	60	60	60	60	60	60	60
	L3/L4	17.3	20	21.7	25	25	25	25	25	20	30
EAL(H)20A	Single	69.3	80	96.7	110	100	110	100	110	100	100
	L1/L2	34.7	40	53.3	60	60	60	60	60	60	60
	L3/L4	34.7	40	43.3	50	45	50	45	50	40	50

All heaters rated single phase 60 cycle and include unit fan load

All fuses type "D" time delay (or HACR circuit breaker in USA)

Vertical rear discharge models use the horizontal (EALH) auxiliary heat kit

Auxiliary Heat Ratings

Model	KW		Stages	BTU/HR		Min CFM	Compatibility			
	208V	230V		208V	230V		038	049	064	072
EAL10A	7.2	9.6	2	24,600	32,700	1100	•	•	•	•
EAL15A	10.8	14.4	3	36,900	49,100	1250	•	•	•	•
EAL20A	14.4	19.2	4	49,200	65,500	1500		•	•	•

NOTES: The heat pump requires Medium and High blower setting to be above the minimum CFM for the heater selected.
Rear discharge uses the horizontal auxiliary heat kits, EALH10A, 15A, or 20A.

5/6/09

Contractor: _____ P.O.: _____

Engineer: _____

Project Name: _____ Unit Tag: _____

**Synergy3D Residential Series
3-6 Ton 60Hz**



Electrical Data

Model	Rated Voltage	Voltage Min/Max	Compressor				Int Pump FLA	Ext Loop FLA	Blower Motor FLA	Total Unit FLA	Min Circ Amp	Max Fuse/HACR
			MCC	RLA	LRA	LRA**						
038	208-230/60/1	187/253	23.8	15.2	83.0	30.0	1.07	5.4	4.0	25.7	29.5	40
038*	208-230/60/1	187/253	23.8	15.2	83.0	30.0	1.07	5.4	7.0	28.7	32.5	45
049	208-230/60/1	187/253	33.0	21.1	104.0	37.0	1.07	5.4	4.0	31.6	36.8	50
049*	208-230/60/1	187/253	33.0	21.1	104.0	37.0	1.07	5.4	7.0	34.6	39.9	60
064	208-230/60/1	187/253	42.3	27.1	152.9	54.0	1.07	5.4	7.0	40.5	47.3	70
072	208-230/60/1	187/253	46.3	29.6	179.2	63.0	1.07	5.4	7.0	43.1	50.5	80

Rated Voltage of 208-230/60/1.
 HACR circuit breaker in USA only.
 Local electrical codes overrule any wiring recommendations.
 * With optional 1 HP ECM motor
 **With optional IntelliStart

Min/Max Voltage of 187/253.
 All fuses Class RK-5.

09/24/13

Contractor: _____ P.O.: _____

Engineer: _____

Project Name: _____ Unit Tag: _____

**Synergy3D Residential Series
3-6 Ton 60Hz**



Blower Performance Data

Model	Max ESP	Air Flow Dip Switch Settings											
		1	2	3	4	5	6	7	8	9	10	11	12
038	0.50	650	750 L	850	1000	1100 M	1200	1300 H	1400	1500			
038 w/1hp*	0.75	800 L	1000	1100 M	1300 H	1500	1600	1800					
049	0.50	650	800 L	900	1050	1150	1250	1350 M	1450	1550 H			
049 w/1hp*	0.75	800 L	900	1000	1200	1400 M	1600 H	1700	1850	2000	2200	2300	2400
064	0.75	800	950 L	1100	1300	1500 M	1750	1950 H	2100	2300			
072	0.75	800	950	1100 L	1300	1500	1750	1950 M	2100 H	2300			

Factory settings are at recommended L-M-H DIP switch locations
M-H settings MUST be located within boldface CFM range
Lowest and Highest DIP switch settings are assumed to be L and H respectively

CFM is controlled within 35% up to the maximum ESP
Max ESP includes allowance for wet coil and standard filter

A 12-position DIP switch package on the heat pump control allows the airflow levels to be set for Low, Medium and High speed when using the variable speed ECM blower motor.

Only three of the DIP switches can be in the "On" position. The first "On" switch (the lowest position number) determines the "Low Speed Blower" setting. The second "On" switch determines the "Medium Speed Blower" setting, and the third "On" switch determines the "High Speed Blower" setting.

The example to the right shows SW1 on the heat pump control board configured for the following 049 airflow settings:

- Low Speed Blower: 800 CFM
- Medium Speed Blower: 1350 CFM
- High Speed Blower: 1550 CFM

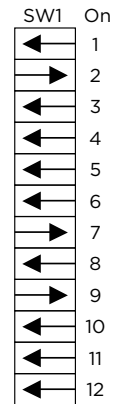

WaterFurnace works continually to improve its products. As a result, the design and specifications of each product at the time of order may be changed without notice. Please contact WaterFurnace at 1-888-929-2837 for latest design and specifications. Purchaser's approval of this data set signifies that the equipment is acceptable under the provisions of the job specification. Statements and other information contained herein are not express warranties and do not form the basis of any bargain between the parties, but are merely WaterFurnace's opinion or commendation of its products. The latest version of this document is available at www.waterfurnace.com.



Contractor: _____ P.O.: _____
 Engineer: _____
 Project Name: _____ Unit Tag: _____

Operating Limits

Operating Limits	Cooling		Heating	
	(°F)	(°C)	(°F)	(°C)
Air Limits				
Min. Ambient Air	45	7.2	45	7.2
Rated Ambient Air	80	26.7	70	21.1
Max. Ambient Air	100	37.8	85	29.4
Min. Entering Air	50	10.0	40	4.4
Rated Entering Air db/wb	80.6/66.2	27/19	68	20.0
Max. Entering Air db/wb	110/83	43/28.3	80	26.7
Water Limits				
Min. Entering Water	30	-1.1	20	-6.7
Normal Entering Water	50-110	10-43.3	30-70	-1.1
Max. Entering Water	120	48.9	90	32.2

NOTE: Minimum/maximum limits are only for start-up conditions, and are meant for bringing the space up to occupancy temperature. Units are not designed to operate at the minimum/maximum conditions on a regular basis. The operating limits are dependant upon three primary factors: 1) water temperature, 2) return air temperature, and 3) ambient temperature. When any of the factors are at the minimum or maximum levels, the other two factors must be at the normal level for proper and reliable unit operation.

Reference Calculations

Heating Calculations:	Cooling Calculations:
$LWT = EWT - \frac{HE}{gpm \times 500}$	$LWT = EWT + \frac{HR}{gpm \times 500}$
$LAT = EAT + \frac{HC}{cfm \times 1.08}$	$LAT (DB) = EAT (DB) - \frac{SC}{cfm \times 1.08}$
$TH = HC + HW$	$LC = TC - SC$
	$S/T = \frac{SC}{TC}$

Legend and Notes

Abbreviations and Definitions

- | | |
|--|--|
| <p>cfm = airflow, cubic feet/minute
 COP = Coefficient of Performance
 = Btu output/Btu input
 = $[HC/(kw \times 3.413)]$
 EAT = entering air temperature, °F
 EER = Energy Efficient Ratio
 = Btu output/Watt input
 ELT = entering load fluid temperature to heat pump
 EST = entering source fluid temperature to heat pump
 EWT = entering water temperature (source) to heat pump
 FT HD = pressure drop in feet of head
 GPM = Gallons per minute
 WPD = water pressure drop, psi and feet of water
 HC = air heating capacity, MBtu/h
 HE = total heat of extraction, MBtu/h
 HR = total heat of rejection, MBtu/h</p> | <p>kW = total power unit input, kilowatts
 LAT = leaving air temperature, °F
 LC = latent cooling capacity, MBtu/h
 LGPM = load flow in gallons per minute
 LLT = leaving load fluid temperature from heat pump
 LST = leaving source fluid temperature from heat pump
 LWPD = load coax water pressure drop
 LWT = leaving water temperature, °F
 PSI = pressure drop in pounds per square inch
 S/T = sensible to total cooling ratio
 SC = sensible cooling capacity, MBtu/h
 SWPD = source coax water pressure drop
 TC = total cooling capacity, MBtu/h
 TH = total heating capacity, MBtu/h
 WPD = water pressure drop in PSI, feet of water</p> |
|--|--|

Notes to Performance Data Tables

The following notes apply to all performance data tables:

- Performance ratings are based on 80°F DB/67°F WB EAT for cooling and 70°F DB EAT for heating.
- Three flow rates are shown for each unit. The lowest flow rate shown is used for geothermal open loop/well water systems with a minimum of 50°F EWT. The middle flow rate shown is the minimum geothermal closed loop flow rate. The highest flow rate shown is optimum for geothermal closed loop systems and the suggested flow rate for boiler/tower applications.
- The hot water generator numbers are based on a flow rate of 0.4 gpm/ton of rated capacity with an EWT of 90°F.
- Entering water temperatures below 40°F assumes 15% antifreeze solution.
- For non-standard EAT conditions, apply the appropriate Correction Factor tables.
- Interpolation between EWT, gpm, and cfm data is permissible, extrapolation is not.
- Pumping power is not included in the Performance Data tables nor are calculations for AHRI/ISO 13256-1.

WaterFurnace works continually to improve its products. As a result, the design and specifications of each product at the time of order may be changed without notice. Please contact WaterFurnace at 1-888-929-2837 for latest design and specifications. Purchaser's approval of this data set signifies that the equipment is acceptable under the provisions of the job specification. Statements and other information contained herein are not express warranties and do not form the basis of any bargain between the parties, but are merely WaterFurnace's opinion or commendation of its products. The latest version of this document is available at www.waterfurnace.com.



Contractor: _____ P.O.: _____
 Engineer: _____
 Project Name: _____ Unit Tag: _____

Correction Factor Tables

Air Flow Corrections (Dual Capacity Part Load)

Airflow		Cooling				Heating		
CFM Per Ton of Clg	% of Nominal	Total Cap	Sens Cap	Power	Heat of Rej	Htg Cap	Power	Heat of Ext
240	60	0.922	0.778	0.956	0.924	0.943	1.239	0.879
275	69	0.944	0.830	0.962	0.944	0.958	1.161	0.914
300	75	0.957	0.866	0.968	0.958	0.968	1.115	0.937
325	81	0.970	0.900	0.974	0.970	0.977	1.075	0.956
350	88	0.982	0.933	0.981	0.980	0.985	1.042	0.972
375	94	0.991	0.968	0.991	0.991	0.993	1.018	0.988
400	100	1.000	1.000	1.000	1.000	1.000	1.000	1.000
425	106	1.007	1.033	1.011	1.008	1.007	0.990	1.010
450	113	1.013	1.065	1.023	1.015	1.012	0.987	1.018
475	119	1.017	1.099	1.037	1.022	1.018	0.984	1.025
500	125	1.020	1.132	1.052	1.027	1.022	0.982	1.031
520	130	1.022	1.159	1.064	1.030	1.025	0.979	1.034

5/30/06

Air Flow Corrections (Dual Capacity Full Load & Single Speed)

Airflow		Cooling				Heating		
CFM Per Ton of Clg	% of Nominal	Total Cap	Sens Cap	Power	Heat of Rej	Htg Cap	Power	Heat of Ext
240	60	0.922	0.786	0.910	0.920	0.943	1.150	0.893
275	69	0.944	0.827	0.924	0.940	0.958	1.105	0.922
300	75	0.959	0.860	0.937	0.955	0.968	1.078	0.942
325	81	0.971	0.894	0.950	0.967	0.977	1.053	0.959
350	88	0.982	0.929	0.964	0.978	0.985	1.031	0.973
375	94	0.992	0.965	0.982	0.990	0.993	1.014	0.988
400	100	1.000	1.000	1.000	1.000	1.000	1.000	1.000
425	106	1.007	1.034	1.020	1.010	1.007	0.990	1.011
450	113	1.012	1.065	1.042	1.018	1.013	0.983	1.020
475	119	1.017	1.093	1.066	1.026	1.018	0.980	1.028
500	125	1.019	1.117	1.092	1.033	1.023	0.978	1.034
520	130	1.020	1.132	1.113	1.038	1.026	0.975	1.038

5/30/06

Cooling Capacity Corrections

Entering Air WB °F	Total Clg Cap	Sensible Cooling Capacity Multipliers - Entering DB °F										Power Input	Heat of Rejection
		60	65	70	75	80	80.6	85	90	95	100		
55	0.898	0.723	0.866	1.048	1.185	*	*	*	*	*	*	0.985	0.913
60	0.912		0.632	0.880	1.078	1.244	1.260	*	*	*	*	0.994	0.927
63	0.945			0.768	0.960	1.150	1.175	*	*	*	*	0.996	0.954
65	0.976			0.694	0.881	1.079	1.085	1.270	*	*	*	0.997	0.972
66.2	0.983			0.655	0.842	1.040	1.060	1.232	*	*	*	0.999	0.986
67	1.000			0.616	0.806	1.000	1.023	1.193	1.330	1.480	*	1.000	1.000
70	1.053				0.693	0.879	0.900	1.075	1.250	1.404	*	1.003	1.044
75	1.168					0.687	0.715	0.875	1.040	1.261	1.476	1.007	1.141

NOTE: *Sensible capacity equals total capacity at conditions shown.

03/28/12

Heating Capacity Corrections

Ent Air DB °F	Heating Corrections		
	Htg Cap	Power	Heat of Ext
45	1.062	0.739	1.158
50	1.050	0.790	1.130
55	1.037	0.842	1.096
60	1.025	0.893	1.064
65	1.012	0.945	1.030
68	1.005	0.976	1.012
70	1.000	1.000	1.000
75	0.987	1.048	0.970
80	0.975	1.099	0.930

11/10/09

WaterFurnace works continually to improve its products. As a result, the design and specifications of each product at the time of order may be changed without notice. Please contact WaterFurnace at 1-888-929-2837 for latest design and specifications. Purchaser's approval of this data set signifies that the equipment is acceptable under the provisions of the job specification. Statements and other information contained herein are not express warranties and do not form the basis of any bargain between the parties, but are merely WaterFurnace's opinion or commendation of its products. The latest version of this document is available at www.waterfurnace.com.

Contractor: _____ P.O.: _____

Engineer: _____

Project Name: _____ Unit Tag: _____

**Synergy3D Residential Series
3-6 Ton 60Hz**



Antifreeze Corrections

Catalog performance can be corrected for antifreeze use. Please use the following table and note the example given.

Antifreeze Type	Antifreeze % by wt	Heating	Cooling	Pressure Drop
EWT - °F [°C]		30 [-1.1]	90 [32.2]	30 [-1.1]
Water	0	1.000	1.000	1.000
Ethylene Glycol	10	0.973	0.991	1.075
	20	0.943	0.979	1.163
	30	0.917	0.965	1.225
	40	0.890	0.955	1.324
	50	0.865	0.943	1.419
Propylene Glycol	10	0.958	0.981	1.130
	20	0.913	0.969	1.270
	30	0.854	0.950	1.433
	40	0.813	0.937	1.614
	50	0.770	0.922	1.816
Ethanol	10	0.927	0.991	1.242
	20	0.887	0.972	1.343
	30	0.856	0.947	1.383
	40	0.815	0.930	1.523
	50	0.779	0.911	1.639
Methanol	10	0.957	0.986	1.127
	20	0.924	0.970	1.197
	30	0.895	0.951	1.235
	40	0.863	0.936	1.323
	50	0.833	0.920	1.399



WARNING: Gray area represents antifreeze concentrations greater than 35% by weight and should be avoided due to the extreme performance penalty they represent.

Antifreeze Correction Example

Antifreeze solution is Propylene Glycol 20% by weight. Determine the corrected heating and cooling performance at 30°F and 90°F respectively as well as pressure drop at 30°F for a Synergy3D Model O38.

The corrected cooling capacity at 90°F would be: 36,800 MBtu/h x 0.969 = 35,659 MBtu/h

The corrected heating capacity at 30°F would be: 26,600 MBtu/h x 0.913 = 24,286 MBtu/h

The corrected pressure drop at 30°F and 9 gpm would be: 7.9 feet of head x 1.270 = 10.03 feet of head

WaterFurnace works continually to improve its products. As a result, the design and specifications of each product at the time of order may be changed without notice. Please contact WaterFurnace at 1-888-929-2837 for latest design and specifications. Purchaser's approval of this data set signifies that the equipment is acceptable under the provisions of the job specification. Statements and other information contained herein are not express warranties and do not form the basis of any bargain between the parties, but are merely WaterFurnace's opinion or commendation of its products. The latest version of this document is available at www.waterfurnace.com.

Contractor: _____ P.O.: _____

Engineer: _____

Project Name: _____ Unit Tag: _____

**Synergy3D Residential Series
3-6 Ton 60Hz**



Pressure Drop

Model	gpm	Pressure Drop (psi)				
		30°F	50°F	70°F	90°F	110°F
038 full load	5	1.2	1.2	1.1	1.0	1.0
	7	2.2	2.1	1.9	1.8	1.7
	9	3.4	3.2	3.0	2.8	2.6
	11	4.9	4.6	4.3	4.0	3.7
038 part load	4	0.9	0.8	0.8	0.7	0.7
	6	1.7	1.6	1.5	1.4	1.3
	8	2.8	2.6	2.5	2.3	2.1
	10	4.2	3.9	3.7	3.4	3.2
049 full load	6	1.2	1.2	1.1	1.0	1.0
	9	2.4	2.2	2.1	2.0	1.8
	12	3.9	3.6	3.4	3.2	2.9
	15	5.7	5.3	5.0	4.7	4.3
049 part load	5	1.1	1.1	1.0	0.9	0.9
	8	2.0	1.8	1.7	1.6	1.5
	11	3.4	3.1	2.9	2.8	2.5
	14	5.0	4.7	4.4	4.1	3.8
064 full load	8	2.0	1.8	1.7	1.6	1.5
	12	3.6	3.3	3.2	3.0	2.6
	16	6.5	6.0	5.6	5.2	4.8
	20	9.7	9.1	8.5	8.0	7.4
064 part load	6	1.2	1.2	1.1	1.0	1.0
	10	2.6	2.5	2.3	2.1	2.0
	14	5.0	4.7	4.4	4.1	3.8
	18	8.1	7.6	7.1	6.6	6.1
072 full load	12	3.6	3.3	3.2	3.0	2.6
	15	5.7	5.3	5.0	4.7	4.3
	18	8.1	7.6	7.1	6.6	6.1
	21	10.8	10.1	9.5	8.9	8.2
072 part load	10	2.6	2.5	2.3	2.1	2.0
	13	4.1	4.0	3.7	3.4	3.3
	16	6.5	6.0	5.8	5.4	5.0
	19	8.9	8.4	7.9	7.4	6.9

6/8/11

WaterFurnace works continually to improve its products. As a result, the design and specifications of each product at the time of order may be changed without notice. Please contact WaterFurnace at 1-888-929-2837 for latest design and specifications. Purchaser's approval of this data set signifies that the equipment is acceptable under the provisions of the job specification. Statements and other information contained herein are not express warranties and do not form the basis of any bargain between the parties, but are merely WaterFurnace's opinion or commendation of its products. The latest version of this document is available at www.waterfurnace.com.

Contractor: _____ P.O.: _____

Engineer: _____

Project Name: _____ Unit Tag: _____

Synergy3D Residential Series 3-6 Ton 60Hz



SDV049 Low Speed - Performance Data

EWT °F	Flow gpm	WPD		HEATING - EAT 70°F							COOLING - EAT 80/67 °F								
		PSI	FT	Airflow cfm	HC MBtu/h	Power kW	HE MBtu/h	LAT °F	COP	HWC MBtu/h	Airflow cfm	TC MBtu/h	SC MBtu/h	S/T Ratio	Power kW	HR MBtu/h	EER	HWC MBtu/h	
20	5.0	1.2	2.7	Operation not recommended							Operation not recommended								
	8.0	2.0	4.6	Operation not recommended							Operation not recommended								
	11.0	3.4	7.8	1150	22.0	2.06	15.0	87.7	3.13	4.1	1350	22.8	2.09	15.7	85.6	3.20	3.7		
30	5.0	1.1	2.6	Operation not recommended							Operation not recommended								
	8.0	1.9	4.5	1150	25.2	2.18	17.8	90.3	3.40	4.2	1150	34.8	22.3	0.64	1.22	38.9	28.6	-	
				1350	26.0	2.19	18.5	87.8	3.48	3.8	1350	35.3	24.4	0.69	1.28	39.7	27.5	-	
	11.0	3.3	7.6	1150	25.9	2.19	18.4	90.8	3.46	4.3	1150	34.9	22.3	0.64	1.18	39.0	29.6	-	
			1350	26.8	2.23	19.2	88.4	3.53	3.9	1350	35.8	24.4	0.68	1.24	40.0	28.9	-		
40	5.0	1.1	2.5	Operation not recommended							Operation not recommended								
	8.0	1.9	4.3	1150	29.2	2.24	21.6	93.5	3.81	4.5	1150	37.6	25.6	0.68	1.37	42.3	27.3	-	
				1350	30.2	2.24	22.6	90.7	3.95	4.2	1350	38.3	27.9	0.73	1.44	43.2	26.5	-	
				1150	30.2	2.26	22.5	94.3	3.91	4.7	1150	37.9	25.6	0.68	1.33	42.4	28.4	-	
			1350	31.2	2.27	23.4	91.4	4.02	4.2	1350	38.7	27.9	0.72	1.40	43.5	27.7	-		
50	5.0	1.1	2.5	1150	30.8	2.24	23.2	94.8	4.04	4.8	1150	39.3	26.5	0.68	1.81	45.5	21.7	1.6	
				1350	31.8	2.24	24.2	91.8	4.17	4.4	1350	40.5	31.3	0.77	1.88	46.9	21.5	1.7	
	8.0	1.8	4.2	1150	33.2	2.31	25.3	96.7	4.21	4.9	1150	40.1	26.7	0.66	1.57	45.5	25.6	1.5	
				1350	34.5	2.29	26.6	93.6	4.40	4.5	1350	41.4	31.4	0.76	1.64	47.0	25.2	1.6	
	11.0	3.1	7.2	1150	34.5	2.32	26.5	97.8	4.35	5.1	1150	40.4	26.7	0.66	1.47	45.4	27.4	1.4	
			1350	35.6	2.32	27.7	94.4	4.49	4.6	1350	41.6	31.4	0.75	1.55	46.9	26.8	1.5		
60	5.0	1.0	2.4	1150	34.2	2.32	26.3	97.5	4.31	5.2	1150	37.7	26.0	0.69	1.98	44.5	19.0	2.3	
				1350	35.4	2.31	27.6	94.3	4.50	4.8	1350	38.9	30.6	0.79	2.07	46.0	18.8	2.4	
	8.0	1.8	4.1	1150	37.0	2.38	28.9	99.8	4.55	5.4	1150	38.3	26.2	0.68	1.76	44.3	21.8	2.1	
				1350	38.4	2.35	30.4	96.4	4.79	5.0	1350	39.5	30.8	0.78	1.84	45.8	21.5	2.3	
	11.0	3.0	6.9	1150	38.6	2.40	30.4	101.1	4.71	5.5	1150	38.8	26.3	0.68	1.67	44.5	23.2	1.9	
			1350	40.0	2.37	31.8	97.4	4.93	5.1	1350	40.0	30.9	0.77	1.75	45.9	22.9	2.2		
70	5.0	1.0	2.3	1150	37.6	2.41	29.4	100.3	4.57	5.8	1150	36.2	25.5	0.71	2.16	43.5	16.8	3.0	
				1350	39.1	2.38	31.0	96.8	4.81	5.4	1350	37.3	30.0	0.80	2.26	45.0	16.5	3.1	
	8.0	1.7	3.9	1150	40.8	2.45	32.5	102.9	4.88	6.0	1150	36.5	25.8	0.70	1.95	43.2	18.7	2.8	
				1350	42.4	2.41	34.2	99.1	5.16	5.5	1350	37.7	30.3	0.80	2.04	44.6	18.5	3.0	
	11.0	2.9	6.7	1150	42.7	2.48	34.2	104.4	5.04	6.1	1150	37.2	25.9	0.70	1.87	43.5	19.9	2.6	
			1350	44.3	2.43	36.0	100.4	5.35	5.7	1350	38.3	30.4	0.79	1.94	44.9	19.7	2.8		
80	5.0	1.0	2.2	1150	40.0	2.47	31.6	102.2	4.75	6.5	1150	34.5	24.8	0.72	2.36	42.6	14.6	4.2	
				1350	41.6	2.43	33.3	98.5	5.02	6.0	1350	35.6	29.2	0.82	2.46	44.0	14.5	4.4	
	8.0	1.6	3.8	1150	43.5	2.50	34.9	105.0	5.10	6.7	1150	34.7	25.1	0.72	2.19	42.2	15.8	3.9	
				1350	45.2	2.44	36.9	101.0	5.44	6.1	1350	35.8	29.5	0.83	2.28	43.5	15.7	4.2	
	11.0	2.8	6.5	1150	45.7	2.53	37.1	106.8	5.30	6.9	1150	35.5	25.3	0.71	2.10	42.7	16.9	3.6	
			1350	47.5	2.46	39.1	102.6	5.66	6.3	1350	36.6	29.8	0.81	2.19	44.1	16.8	4.0		
90	5.0	0.9	2.2	1150	42.4	2.53	33.8	104.2	4.91	7.2	1150	32.9	24.2	0.73	2.56	41.7	12.9	5.4	
				1350	44.1	2.48	35.6	100.2	5.22	6.7	1350	34.0	28.4	0.84	2.67	43.1	12.7	5.7	
	8.0	1.6	3.7	1150	46.1	2.55	37.4	107.1	5.31	7.4	1150	32.9	24.5	0.74	2.43	41.2	13.6	5.0	
				1350	48.0	2.46	39.6	102.9	5.72	6.9	1350	33.9	28.8	0.85	2.52	42.4	13.4	5.5	
	11.0	2.7	6.2	1150	48.7	2.57	39.9	109.2	5.54	7.7	1150	33.9	24.7	0.73	2.33	41.8	14.5	4.7	
			1350	50.7	2.49	42.2	104.8	5.97	7.1	1350	34.9	29.1	0.83	2.43	43.2	14.4	5.2		
100	5.0	0.9	2.1	Operation not recommended							Operation not recommended								
	8.0	1.5	3.5	Operation not recommended							1150	30.6	23.7	0.78	2.73	39.9	11.2	3.6	
				Operation not recommended							1350	31.5	28.0	0.89	2.84	41.2	11.1	3.9	
110	11.0	2.6	6.0	Operation not recommended							1150	31.7	24.1	0.76	2.63	40.7	12.1	3.3	
	5.0	0.9	2.0	Operation not recommended							Operation not recommended								
	8.0	1.5	3.4	Operation not recommended							1150	28.2	23.0	0.82	3.03	38.6	9.3	4.4	
				Operation not recommended							1350	29.2	27.1	0.93	3.15	39.9	9.3	4.7	
			Operation not recommended							1150	29.6	23.4	0.79	2.93	39.6	10.1	4.1		
			Operation not recommended							1350	30.4	27.5	0.90	3.06	40.8	9.9	4.5		
120	5.0	0.8	1.9	Operation not recommended							Operation not recommended								
	8.0	1.4	3.3	Operation not recommended							1150	26.9	24.4	0.91	3.43	38.6	7.8	5.3	
				Operation not recommended							1350	27.4	26.5	0.97	3.52	39.4	7.8	5.7	
	11.0	2.4	5.6	Operation not recommended							1150	27.1	24.4	0.90	3.32	38.4	8.2	4.9	
			Operation not recommended							1350	27.7	26.5	0.96	3.42	39.4	8.1	5.4		

Performance capacities shown in thousands of Btu/h.

11/11/13

IMPORTANT NOTE: Refer to Notes to Performance Tables for additional information.

WaterFurnace works continually to improve its products. As a result, the design and specifications of each product at the time of order may be changed without notice. Please contact WaterFurnace at 1-888-929-2837 for latest design and specifications. Purchaser's approval of this data set signifies that the equipment is acceptable under the provisions of the job specification. Statements and other information contained herein are not express warranties and do not form the basis of any bargain between the parties, but are merely WaterFurnace's opinion or commendation of its products. The latest version of this document is available at www.waterfurnace.com.

Contractor: _____ P.O.: _____

Engineer: _____

Project Name: _____ Unit Tag: _____

Synergy3D Residential Series 3-6 Ton 60Hz



SDV049 High Speed - Performance Data

EWT °F	Flow gpm	WPD		HEATING - EAT 70°F							COOLING - EAT 80/67 °F							
		PSI	FT	Airflow cfm	HC MBtu/h	Power kW	HE MBtu/h	LAT °F	COP	HWC MBtu/h	Airflow cfm	TC MBtu/h	SC MBtu/h	S/T Ratio	Power kW	HR MBtu/h	EER	HWC MBtu/h
20	6.0	1.3	3.0	Operation not recommended							Operation not recommended							
	9.0	2.5	5.7															
	12.0	4.0	9.2	1350	27.4	2.57	18.6	88.8	3.12	4.7								
				1550	28.4	2.61	19.5	87.0	3.19	4.2								
30	6.0	1.2	2.9	Operation not recommended							Operation not recommended							
	9.0	2.4	5.5	1350	30.6	2.54	21.9	91.0	3.53	4.9	1350	41.5	26.7	0.64	1.75	47.4	23.7	-
				1550	31.6	2.56	22.8	88.9	3.61	4.5	1550	42.1	29.2	0.69	1.84	48.4	22.9	-
				1350	31.4	2.56	22.6	91.5	3.59	5.0	1350	41.7	26.7	0.64	1.70	47.5	24.6	-
				1550	32.5	2.60	23.6	89.4	3.67	4.6	1550	42.7	29.2	0.68	1.78	48.8	24.0	-
40	6.0	1.2	2.8	Operation not recommended							Operation not recommended							
	9.0	2.3	5.3	1350	35.5	2.71	26.2	94.3	3.84	5.6	1350	44.2	30.6	0.69	1.95	50.8	22.7	-
				1550	36.7	2.71	27.5	91.9	3.97	5.2	1550	45.0	33.5	0.74	2.04	52.0	22.0	-
				1350	36.6	2.73	27.3	95.1	3.94	5.8	1350	44.5	30.6	0.69	1.89	50.9	23.6	-
				1550	37.9	2.75	28.5	92.6	4.04	5.3	1550	45.5	33.5	0.74	1.98	52.2	23.0	-
50	6.0	1.2	2.7	1350	37.5	2.79	28.0	95.7	3.94	6.1	1350	45.6	31.8	0.70	2.53	54.2	18.0	2.7
				1550	38.7	2.79	29.2	93.1	4.07	5.6	1550	47.0	37.5	0.80	2.64	56.0	17.8	2.9
	9.0	2.2	5.2	1350	40.4	2.88	30.6	97.7	4.11	6.3	1350	46.6	32.0	0.69	2.19	54.1	21.3	2.5
				1550	41.9	2.86	32.2	95.0	4.30	5.8	1550	48.0	37.7	0.79	2.30	55.9	20.9	2.7
				1350	41.9	2.90	32.0	98.8	4.24	6.5	1350	46.9	32.0	0.68	2.06	53.9	22.7	2.3
			1550	43.3	2.90	33.4	95.9	4.38	5.9	1550	48.3	37.7	0.78	2.17	55.7	22.3	2.6	
60	6.0	1.1	2.6	1350	41.4	2.92	31.4	98.4	4.15	6.9	1350	44.2	31.6	0.72	2.70	53.4	16.4	3.2
				1550	42.8	2.90	32.9	95.6	4.33	6.4	1550	45.6	37.3	0.82	2.82	55.2	16.2	3.4
	9.0	2.2	5.0	1350	44.7	2.99	34.5	100.7	4.38	7.1	1350	44.9	31.9	0.71	2.40	53.1	18.8	3.0
				1550	46.5	2.96	36.4	97.8	4.61	6.6	1550	46.3	37.5	0.81	2.51	54.8	18.5	3.2
				1350	46.6	3.02	36.3	102.0	4.53	7.3	1350	45.4	32.0	0.70	2.27	53.2	20.0	2.7
			1550	48.3	2.98	38.1	98.9	4.74	6.7	1550	46.8	37.6	0.80	2.38	54.9	19.7	3.1	
70	6.0	1.1	2.5	1350	45.3	3.05	34.9	101.1	4.34	7.9	1350	42.8	31.4	0.74	2.87	52.5	14.9	3.9
				1550	47.0	3.02	36.7	98.1	4.57	7.3	1550	44.1	37.0	0.84	3.00	54.4	14.7	4.2
	9.0	2.1	4.9	1350	49.1	3.11	38.5	103.7	4.63	8.1	1350	43.2	31.8	0.74	2.60	52.1	16.6	3.7
				1550	51.1	3.05	40.6	100.5	4.90	7.5	1550	44.6	37.3	0.84	2.71	53.8	16.4	4.0
				1350	51.4	3.14	40.6	105.2	4.79	8.4	1350	44.0	31.9	0.73	2.48	52.4	17.7	3.4
			1550	53.3	3.07	42.8	101.8	5.09	7.7	1550	45.3	37.5	0.83	2.58	54.1	17.6	3.8	
80	6.0	1.1	2.5	1350	47.4	3.16	36.6	102.5	4.40	8.7	1350	41.0	29.8	0.73	2.97	51.1	13.8	5.1
				1550	49.2	3.10	38.6	99.4	4.65	8.1	1550	42.3	35.0	0.83	3.09	52.8	13.7	5.4
	9.0	2.0	4.7	1350	51.5	3.19	40.6	105.3	4.72	9.0	1350	41.2	30.1	0.73	2.75	50.6	15.0	4.7
				1550	53.6	3.11	42.9	102.0	5.04	8.3	1550	42.4	35.4	0.83	2.86	52.2	14.8	5.1
				1350	54.1	3.23	43.1	107.1	4.91	9.3	1350	42.1	30.3	0.72	2.63	51.1	16.0	4.4
			1550	56.3	3.14	45.5	103.6	5.25	8.6	1550	43.4	35.6	0.82	2.75	52.8	15.8	4.9	
90	6.0	1.0	2.4	1350	49.5	3.26	38.4	104.0	4.45	9.7	1350	39.2	28.1	0.72	3.07	49.6	12.8	6.3
				1550	51.5	3.19	40.6	100.7	4.73	9.0	1550	40.4	33.0	0.82	3.19	51.3	12.7	6.7
	9.0	2.0	4.5	1350	53.8	3.28	42.7	106.9	4.81	10.0	1350	39.2	28.4	0.73	2.91	49.1	13.5	5.9
				1550	56.1	3.17	45.3	103.5	5.18	9.3	1550	40.3	33.5	0.83	3.02	50.5	13.3	6.4
				1350	56.8	3.31	45.5	109.0	5.03	10.3	1350	40.3	28.7	0.71	2.79	49.8	14.4	5.5
			1550	59.2	3.21	48.3	105.4	5.41	9.6	1550	41.5	33.8	0.81	2.91	51.4	14.3	6.1	
100	6.0	1.0	2.3	Operation not recommended							Operation not recommended							
	9.0	1.9	4.4															
	12.0	3.1	7.1															
110	6.0	1.0	2.2	Operation not recommended							Operation not recommended							
	9.0	1.8	4.2															
				1350	34.4	26.7	0.78	3.71	47.1	9.3	9.3							
				1550	35.6	31.4	0.88	3.87	48.7	9.2	10.1							
				1350	36.0	27.2	0.75	3.60	48.3	10.0	8.7							
			1550	37.0	31.9	0.86	3.75	49.8	9.9	9.6								
120	6.0	0.9	2.1	Operation not recommended							Operation not recommended							
	9.0	1.7	4.0															
	12.0	2.8	6.5															
			1350	33.1	28.5	0.86	4.15	47.2	8.0	11.3								
			1550	33.7	31.0	0.92	4.26	48.2	7.9	12.2								
			1350	33.4	28.5	0.85	4.01	47.1	8.3	10.5								
			1550	34.1	31.0	0.91	4.14	48.2	8.2	11.6								

Performance capacities shown in thousands of Btu/h.

11/11/13

IMPORTANT NOTE: Refer to Notes to Performance Tables for additional information.

WaterFurnace works continually to improve its products. As a result, the design and specifications of each product at the time of order may be changed without notice. Please contact WaterFurnace at 1-888-929-2837 for latest design and specifications. Purchaser's approval of this data set signifies that the equipment is acceptable under the provisions of the job specification. Statements and other information contained herein are not express warranties and do not form the basis of any bargain between the parties, but are merely WaterFurnace's opinion or commendation of its products. The latest version of this document is available at www.waterfurnace.com.

Contractor: _____ P.O.: _____

Engineer: _____

Project Name: _____ Unit Tag: _____

Synergy3D Residential Series
3-6 Ton 60Hz



SDV064 Low Speed - Performance Data

EWT °F	Flow gpm	WPD		HEATING - EAT 70°F							COOLING - EAT 80/67 °F							
		PSI	FT	Airflow cfm	HC MBtu/h	Power kW	HE MBtu/h	LAT °F	COP	HWC MBtu/h	Airflow cfm	TC MBtu/h	SC MBtu/h	S/T Ratio	Power kW	HR MBtu/h	EER	HWC MBtu/h
20	6.0	1.3	3.0	Operation not recommended														
	10.0	2.7	6.2	Operation not recommended														
	14.0	5.1	11.9	1250	24.6	2.71	15.3	88.2	2.65	4.6	Operation not recommended							
				1500	25.4	2.75	16.0	85.7	2.71	4.2								
30	6.0	1.2	2.9	Operation not recommended														
	10.0	2.6	6.0	1250	28.1	2.77	18.6	90.8	2.97	4.6	1250	46.4	30.8	0.66	1.57	51.8	29.5	-
				1500	29.1	2.81	19.5	88.0	3.04	4.2	1500	47.2	33.7	0.71	1.66	52.8	28.5	-
				1250	29.1	2.77	19.6	91.6	3.08	4.7	1250	46.7	30.8	0.66	1.52	51.9	30.6	-
	14.0	5.0	11.6	1500	30.1	2.81	20.5	88.6	3.14	4.3	1500	47.8	33.7	0.70	1.60	53.3	29.9	-
	40	6.0	1.2	2.8	Operation not recommended													
10.0		2.5	5.9	1250	33.7	2.87	23.9	95.0	3.44	5.1	1250	49.1	32.9	0.67	1.79	55.2	27.4	-
				1500	34.7	2.88	24.8	91.4	3.52	4.6	1500	50.0	35.9	0.72	1.88	56.4	26.6	-
				1250	34.8	2.88	25.0	95.8	3.54	5.2	1250	49.4	32.9	0.67	1.74	55.4	28.4	-
14.0		4.8	11.2	1500	35.8	2.89	25.9	92.1	3.62	4.8	1500	50.6	35.9	0.71	1.82	56.8	27.8	-
50		6.0	1.2	2.7	1250	38.7	2.92	28.7	98.7	3.88	5.3	1250	51.5	33.4	0.65	2.06	58.5	25.0
	1500				39.8	2.92	29.8	94.5	3.98	4.9	1500	53.0	37.9	0.72	2.17	60.4	24.4	2.0
	10.0	2.5	5.7	1250	39.3	2.98	29.1	99.1	3.87	5.5	1250	51.7	33.7	0.65	1.98	58.4	26.0	1.8
				1500	40.2	2.96	30.1	94.8	3.98	5.1	1500	53.2	38.2	0.72	2.08	60.3	25.6	1.9
				1250	40.5	3.00	30.3	100.0	3.96	5.7	1250	51.8	33.7	0.65	1.95	58.4	26.6	1.6
	14.0	4.7	10.9	1500	41.4	2.98	31.2	95.6	4.07	5.2	1500	53.3	38.2	0.72	2.04	60.3	26.1	1.8
60	6.0	1.1	2.6	1250	43.9	3.02	33.6	102.5	4.26	6.0	1250	49.4	32.8	0.66	2.30	57.3	21.5	2.6
				1500	44.8	3.00	34.6	97.7	4.38	5.5	1500	50.9	37.0	0.73	2.41	59.1	21.2	2.8
	10.0	2.4	5.5	1250	45.3	3.08	34.8	103.5	4.31	6.1	1250	49.7	33.1	0.67	2.23	57.2	22.3	2.5
				1500	46.0	3.03	35.6	98.4	4.44	5.7	1500	51.1	37.4	0.73	2.33	59.1	22.0	2.7
				1250	46.3	3.10	35.7	104.3	4.38	6.3	1250	49.9	33.2	0.67	2.18	57.3	22.9	2.3
	14.0	4.5	10.5	1500	47.1	3.06	36.6	99.0	4.51	5.8	1500	51.4	37.5	0.73	2.28	59.1	22.5	2.5
70	6.0	1.1	2.5	1250	49.1	3.12	38.4	106.4	4.61	6.7	1250	47.3	32.2	0.68	2.54	56.0	18.7	3.7
				1500	49.9	3.07	39.4	100.8	4.77	6.2	1500	48.8	36.1	0.74	2.64	57.8	18.5	3.9
	10.0	2.3	5.3	1250	51.2	3.17	40.3	107.9	4.73	7.0	1250	47.6	32.5	0.68	2.47	56.1	19.3	3.4
				1500	51.7	3.10	41.1	101.9	4.89	6.4	1500	49.1	36.5	0.74	2.57	57.9	19.1	3.7
				1250	52.1	3.21	41.2	108.6	4.76	7.2	1250	47.9	32.6	0.68	2.41	56.2	19.9	3.2
	14.0	4.4	10.2	1500	52.7	3.14	42.0	102.5	4.92	6.6	1500	49.4	36.7	0.74	2.52	58.0	19.6	3.5
80	6.0	1.1	2.5	1250	52.9	3.19	42.0	109.2	4.86	7.4	1250	44.8	31.3	0.70	2.85	54.6	15.7	5.1
				1500	53.4	3.12	42.7	102.9	5.01	6.9	1500	46.2	35.0	0.76	2.95	56.3	15.7	5.4
	10.0	2.2	5.1	1250	55.9	3.24	44.8	111.4	5.05	7.7	1250	45.2	31.6	0.70	2.78	54.7	16.3	4.8
				1500	56.1	3.15	45.4	104.7	5.23	7.1	1500	46.6	35.4	0.76	2.89	56.4	16.1	5.2
				1250	56.5	3.29	45.3	111.9	5.04	7.9	1250	45.5	31.9	0.70	2.74	54.9	16.6	4.4
	14.0	4.3	9.8	1500	56.8	3.19	45.9	105.0	5.21	7.3	1500	47.0	35.6	0.76	2.84	56.6	16.6	4.9
90	6.0	1.0	2.4	1250	56.7	3.26	45.6	112.0	5.10	8.3	1250	42.3	30.5	0.72	3.17	53.1	13.4	6.8
				1500	56.9	3.17	46.0	105.1	5.25	7.7	1500	43.6	33.8	0.78	3.26	54.7	13.4	7.2
	10.0	2.1	5.0	1250	60.5	3.31	49.2	114.8	5.36	8.6	1250	42.8	30.8	0.72	3.10	53.3	13.8	6.4
				1500	60.5	3.19	49.7	107.4	5.56	7.9	1500	44.0	34.3	0.78	3.20	55.0	13.7	6.9
				1250	60.9	3.36	49.5	115.1	5.31	8.8	1250	43.1	31.1	0.72	3.06	53.5	14.1	5.9
	14.0	4.1	9.5	1500	60.8	3.24	49.7	107.5	5.50	8.2	1500	44.5	34.6	0.78	3.15	55.2	14.1	6.6
100	6.0	1.0	2.3	Operation not recommended														
	10.0	2.1	4.8	1250	39.7	29.8	0.75	3.52	51.7	11.3	8.3	Operation not recommended						
				1500	40.9	33.0	0.81	3.61	53.2	11.3	8.9							
				1250	40.1	30.2	0.75	3.47	52.0	11.6	7.7							
	14.0	4.0	9.1	1500	41.4	33.4	0.81	3.56	53.5	11.6	8.5							
110	6.0	1.0	2.2	Operation not recommended														
	10.0	2.0	4.6	1250	36.7	28.9	0.79	3.94	50.1	9.3	10.4	Operation not recommended						
				1500	37.8	31.7	0.84	4.02	51.5	9.4	11.3							
				1250	37.1	29.4	0.79	3.88	50.4	9.6	9.7							
	14.0	3.8	8.8	1500	38.3	32.2	0.84	3.96	51.8	9.7	10.7							
120	6.0	0.9	2.1	Operation not recommended														
	10.0	1.9	4.4	1250	33.9	28.2	0.83	4.44	49.0	7.6	12.6	Operation not recommended						
				1500	34.5	30.6	0.89	4.55	50.0	7.6	13.6							
				1250	34.2	28.2	0.83	4.29	48.8	8.0	11.7							
	14.0	3.7	8.4	1500	34.9	30.6	0.88	4.43	50.0	7.9	12.9							

Performance capacities shown in thousands of Btu/h.

11/11/13

IMPORTANT NOTE: Refer to Notes to Performance Tables for additional information.

WaterFurnace works continually to improve its products. As a result, the design and specifications of each product at the time of order may be changed without notice. Please contact WaterFurnace at 1-888-929-2837 for latest design and specifications. Purchaser's approval of this data set signifies that the equipment is acceptable under the provisions of the job specification. Statements and other information contained herein are not express warranties and do not form the basis of any bargain between the parties, but are merely WaterFurnace's opinion or commendation of its products. The latest version of this document is available at www.waterfurnace.com.

**Synergy3D Residential Series
3-6 Ton 60Hz**

Contractor: _____ P.O.: _____

Engineer: _____

Project Name: _____ Unit Tag: _____



SDV064 High Speed - Performance Data

EWT °F	Flow gpm	WPD		HEATING - EAT 70°F							COOLING - EAT 80/67 °F										
		PSI	FT	Airflow cfm	HC MBtu/h	Power kW	HE MBtu/h	LAT °F	COP	HWC MBtu/h	Airflow cfm	TC MBtu/h	SC MBtu/h	S/T Ratio	Power kW	HR MBtu/h	EER	HWC MBtu/h			
20	8.0	2.0	4.6	Operation not recommended																	
	12.0	4.0	9.2	Operation not recommended																	
	16.0	6.6	15.1	1500	36.5	3.46	24.7	92.5	3.10	5.7	1800	37.4	3.62	25.1	89.2	3.03	5.2				
30	8.0	1.9	4.5	Operation not recommended																	
	12.0	3.9	8.9	Operation not recommended																	
	16.0	6.4	14.7	1500	42.6	3.56	30.4	96.3	3.50	6.1	1500	62.4	40.9	0.66	2.76	71.9	22.6	-			
				1800	43.7	3.79	30.8	92.5	3.38	5.6	1800	63.5	44.7	0.70	2.91	73.4	21.8	-			
				1500	43.2	3.65	30.7	96.6	3.46	6.3	1500	62.8	40.9	0.65	2.68	71.9	23.5	-			
1800	44.2	3.82	31.2	92.7	3.39	5.7	1800	64.3	44.7	0.70	2.81	73.9	22.9	-							
40	8.0	1.9	4.3	Operation not recommended																	
	12.0	3.7	8.7	Operation not recommended																	
	16.0	6.2	14.3	1500	49.5	3.81	36.5	100.6	3.81	6.9	1500	65.6	42.6	0.65	3.05	76.0	21.5	-			
				1800	50.6	3.97	37.1	96.0	3.74	6.3	1800	66.8	46.6	0.70	3.20	77.8	20.9	-			
				1500	50.3	3.87	37.0	101.0	3.80	7.1	1500	66.1	42.6	0.64	2.96	76.2	22.3	-			
1800	51.4	4.01	37.7	96.4	3.76	6.5	1800	67.6	46.6	0.69	3.10	78.2	21.8	-							
50	8.0	1.8	4.2	Operation not recommended																	
	12.0	3.6	8.4	1500	53.3	3.97	39.8	102.9	3.93	7.4	1500	68.1	43.7	0.64	3.30	79.4	20.6	3.8			
				1800	54.5	4.10	40.5	98.0	3.90	6.9	1800	69.5	47.5	0.68	3.51	81.5	19.8	4.0			
	16.0	6.0	13.8	1500	56.4	4.05	42.6	104.8	4.08	7.7	1500	68.8	44.1	0.64	3.24	79.9	21.3	3.6			
				1800	57.6	4.15	43.4	99.6	4.07	7.1	1800	70.2	48.0	0.68	3.44	81.9	20.4	3.9			
1500				57.4	4.10	43.4	105.4	4.11	7.9	1500	69.5	44.6	0.64	3.18	80.4	21.9	3.3				
1800	58.6	4.20	44.3	100.1	4.09	7.2	1800	70.9	48.4	0.68	3.38	82.4	21.0	3.7							
60	8.0	1.8	4.1	Operation not recommended																	
	12.0	3.5	8.1	1500	60.0	4.25	45.5	107.0	4.14	8.3	1500	66.5	43.3	0.65	3.56	78.6	18.7	4.6			
				1800	61.3	4.32	46.5	101.5	4.16	7.7	1800	68.2	47.0	0.69	3.79	81.1	18.0	4.9			
				1500	62.7	4.32	48.0	108.7	4.26	8.6	1500	67.1	43.7	0.65	3.49	79.1	19.2	4.3			
	16.0	5.8	13.4	1800	64.1	4.37	49.1	102.9	4.29	7.9	1800	68.9	47.5	0.69	3.71	81.5	18.6	4.7			
1500				64.1	4.37	49.2	109.5	4.30	8.9	1500	67.8	44.1	0.65	3.43	79.5	19.8	4.0				
1800	65.5	4.42	50.4	103.7	4.35	8.1	1800	69.6	48.0	0.69	3.65	82.0	19.1	4.4							
70	8.0	1.7	3.9	Operation not recommended																	
	12.0	3.4	7.9	1500	66.5	4.52	51.1	111.1	4.32	9.4	1500	64.8	42.9	0.66	3.82	77.9	17.0	5.6			
				1800	68.0	4.54	52.5	105.0	4.39	8.7	1800	66.8	46.6	0.70	4.07	80.7	16.4	6.0			
				1500	69.0	4.58	53.4	112.6	4.41	9.7	1500	65.4	43.3	0.66	3.75	78.2	17.5	5.3			
	16.0	5.6	12.9	1800	70.5	4.59	54.9	106.3	4.50	8.9	1800	67.6	47.0	0.70	3.98	81.2	17.0	5.7			
1500				70.7	4.64	54.9	113.7	4.47	10.0	1500	66.1	43.7	0.66	3.68	78.7	17.9	4.9				
1800	72.4	4.64	56.6	107.2	4.58	9.2	1800	68.2	47.5	0.70	3.92	81.6	17.4	5.4							
80	8.0	1.6	3.8	Operation not recommended																	
	12.0	3.3	7.6	1500	71.6	4.75	55.4	114.2	4.42	10.3	1500	61.6	41.5	0.67	4.15	75.7	14.8	7.3			
				1800	73.2	4.72	57.1	107.7	4.54	9.6	1800	63.8	45.1	0.71	4.42	78.9	14.5	7.7			
				1500	73.3	4.81	56.9	115.2	4.47	10.7	1500	62.2	41.9	0.67	4.07	76.1	15.3	6.8			
	16.0	5.4	12.5	1800	75.0	4.76	58.8	108.6	4.62	9.9	1800	64.5	45.5	0.71	4.33	79.3	14.9	7.4			
1500				75.5	4.87	58.9	116.6	4.55	11.0	1500	62.8	42.4	0.67	4.00	76.4	15.7	6.3				
1800	77.4	4.81	61.0	109.8	4.72	10.1	1800	65.2	46.0	0.71	4.26	79.7	15.3	7.0							
90	8.0	1.6	3.7	Operation not recommended																	
	12.0	3.2	7.3	1500	76.6	4.98	59.6	117.3	4.51	11.4	1500	58.3	40.2	0.69	4.47	73.5	13.0	9.3			
				1800	78.4	4.91	61.7	110.4	4.69	10.5	1800	60.9	43.7	0.72	4.76	77.1	12.8	9.8			
				1500	77.6	5.03	60.4	117.9	4.52	11.7	1500	59.0	40.5	0.69	4.38	73.9	13.4	8.6			
	16.0	5.2	12.1	1800	79.6	4.93	62.7	110.9	4.73	10.9	1800	61.4	44.1	0.72	4.67	77.3	13.2	9.4			
1500				80.3	5.10	62.9	119.6	4.62	12.1	1500	59.5	41.0	0.69	4.31	74.2	13.8	8.0				
1800	82.4	4.98	65.4	112.4	4.85	11.2	1800	62.1	44.5	0.72	4.59	77.8	13.5	8.9							
100	8.0	1.5	3.5	Operation not recommended																	
	12.0	3.1	7.1	Operation not recommended																	
	16.0	5.0	11.6	Operation not recommended																	
110	8.0	1.5	3.4	Operation not recommended																	
	12.0	2.9	6.8	Operation not recommended																	
				1500	50.8	37.3	0.74	5.21	68.6	9.8	13.6	1500	50.8	37.3	0.74	5.21	68.6	9.8	13.6		
				1800	53.5	40.5	0.76	5.55	72.5	9.6	14.8	1800	53.5	40.5	0.76	5.55	72.5	9.6	14.8		
16.0	4.8	11.2	1500	51.3	37.7	0.74	5.11	68.7	10.0	12.7	1500	51.3	37.7	0.74	5.11	68.7	10.0	12.7			
			1800	54.0	41.0	0.76	5.46	72.6	9.9	14.1	1800	54.0	41.0	0.76	5.46	72.6	9.9	14.1			
120	8.0	1.4	3.3	Operation not recommended																	
	12.0	2.8	6.5	Operation not recommended																	
				1500	48.4	36.0	0.74	6.04	69.0	8.0	16.5	1500	48.4	36.0	0.74	6.04	69.0	8.0	16.5		
				1800	49.3	39.1	0.79	6.20	70.5	8.0	17.9	1800	49.3	39.1	0.79	6.20	70.5	8.0	17.9		
16.0	4.6	10.7	1500	48.9	36.0	0.74	5.85	68.8	8.4	15.3	1500	48.9	36.0	0.74	5.85	68.8	8.4	15.3			
1800	49.9	39.1	0.78	6.03	70.5	8.3	17.0	1800	49.9	39.1	0.78	6.03	70.5	8.3	17.0						

Performance capacities shown in thousands of Btu/h.

11/11/13

IMPORTANT NOTE: Refer to Notes to Performance Tables for additional information.

WaterFurnace works continually to improve its products. As a result, the design and specifications of each product at the time of order may be changed without notice. Please contact WaterFurnace at 1-888-929-2837 for latest design and specifications. Purchaser's approval of this data set signifies that the equipment is acceptable under the provisions of the job specification. Statements and other information contained herein are not express warranties and do not form the basis of any bargain between the parties, but are merely WaterFurnace's opinion or commendation of its products. The latest version of this document is available at www.waterfurnace.com.

Contractor: _____ P.O.: _____
 Engineer: _____
 Project Name: _____ Unit Tag: _____

Synergy3D Residential Series
3-6 Ton 60Hz



SDV072 Performance Data - Low Speed

EWT °F	Flow gpm	WPD		HEATING - EAT 70°F							COOLING - EAT 80/67 °F							
		PSI	FT	Airflow cfm	HC MBtu/h	Power kW	HE MBtu/h	LAT °F	COP	HWC MBtu/h	Airflow cfm	TC MBtu/h	SC MBtu/h	S/T Ratio	Power kW	HR MBtu/h	EER	HWC MBtu/h
20	10.0	2.7	6.2	Operation not recommended							Operation not recommended							
	13.0	3.5	8.1															
	16.0	6.8	15.7	1400	31.7	3.46	19.9	91.0	2.69	5.9								
				1700	33.2	3.50	21.3	88.1	2.78	5.3								
30	10.0	2.6	6.0	Operation not recommended							Operation not recommended							
	13.0	3.4	7.9	1400	32.9	3.50	21.0	91.8	2.76	5.5	1400	53.8	33.7	0.63	2.30	61.6	23.4	-
				1700	34.5	3.54	22.4	88.8	2.86	5.0	1700	54.6	36.9	0.67	2.42	62.9	22.6	-
	16.0	6.6	15.2	1400	34.3	3.50	22.4	92.7	2.88	5.7	1400	54.0	33.7	0.62	2.23	61.6	24.2	-
				1700	36.0	3.54	23.9	89.6	2.98	5.1	1700	55.4	36.9	0.67	2.34	63.3	23.7	-
40	10.0	2.5	5.9	Operation not recommended							Operation not recommended							
	13.0	3.3	7.6	1400	40.9	3.65	28.5	97.1	3.29	6.5	1400	53.7	33.8	0.63	2.31	61.6	23.3	-
				1700	42.7	3.66	30.2	93.3	3.42	5.9	1700	54.7	36.9	0.67	2.42	63.0	22.6	-
	16.0	6.4	14.8	1400	42.4	3.66	29.9	98.0	3.39	6.7	1400	54.1	33.8	0.62	2.24	61.8	24.2	-
				1700	44.3	3.67	31.7	94.1	3.53	6.1	1700	58.6	39.3	0.67	2.57	67.3	22.8	-
50	10.0	2.5	5.7	1400	40.6	3.63	28.3	96.9	3.28	6.8	1400	59.6	36.4	0.61	2.82	69.3	21.1	2.3
				1700	42.5	3.59	30.2	93.1	3.46	6.3	1700	61.5	41.3	0.67	2.97	71.6	20.7	2.4
	13.0	3.2	7.4	1400	41.2	3.67	28.7	97.3	3.29	7.0	1400	59.8	36.7	0.61	2.73	69.1	21.9	2.1
				1700	42.9	3.65	30.4	93.4	3.44	6.4	1700	61.6	41.7	0.68	2.87	71.4	21.5	2.3
	16.0	6.2	14.3	1400	42.5	3.69	29.9	98.1	3.37	7.2	1400	59.9	36.7	0.61	2.66	69.0	22.6	2.0
			1700	52.6	3.80	39.6	98.6	4.05	6.6	1700	61.8	41.7	0.68	2.80	71.3	22.1	2.2	
60	10.0	2.4	5.5	1400	40.5	3.66	28.0	96.8	3.24	7.5	1400	53.3	32.2	0.61	2.37	61.3	22.5	3.2
				1700	42.2	3.58	29.9	93.0	3.45	6.9	1700	54.9	36.4	0.66	2.47	63.3	22.2	3.4
	13.0	3.1	7.2	1400	41.6	3.70	29.0	97.5	3.30	7.7	1400	53.5	32.6	0.61	2.29	61.3	23.4	3.0
				1700	43.2	3.63	30.9	93.6	3.49	7.1	1700	55.1	36.8	0.67	2.39	63.2	23.0	3.2
	16.0	6.0	13.9	1400	42.6	3.74	29.8	98.1	3.34	7.9	1400	53.7	32.6	0.61	2.24	61.4	23.9	2.8
			1700	59.5	3.92	46.2	102.4	4.45	7.3	1700	60.0	41.6	0.69	3.07	70.5	19.6	3.1	
70	10.0	2.3	5.3	1400	40.3	3.69	27.7	96.7	3.20	8.3	1400	53.1	32.3	0.61	2.37	61.1	22.4	4.4
				1700	42.0	3.58	29.8	92.9	3.44	7.7	1700	54.6	36.3	0.67	2.46	63.0	22.2	4.6
	13.0	3.0	6.9	1400	41.9	3.73	29.1	97.7	3.29	8.5	1400	53.4	32.7	0.61	2.29	61.2	23.3	4.1
				1700	43.5	3.62	31.2	93.7	3.53	7.9	1700	54.9	36.7	0.67	2.39	63.0	23.0	4.4
	16.0	5.8	13.4	1400	42.6	3.78	29.7	98.2	3.30	8.8	1400	53.7	32.8	0.61	2.26	61.4	23.7	3.8
			1700	66.5	4.04	52.7	106.2	4.83	8.1	1700	58.3	41.5	0.71	3.34	69.7	17.5	4.2	
80	10.0	2.2	5.1	1400	40.2	3.71	27.5	96.6	3.17	9.2	1400	52.9	32.4	0.61	2.37	61.0	22.3	6.2
				1700	41.7	3.58	29.4	92.7	3.41	8.5	1700	54.4	36.2	0.67	2.44	62.8	22.3	6.6
	13.0	2.9	6.7	1400	42.3	3.76	29.5	98.0	3.30	9.5	1400	53.3	32.8	0.62	2.31	61.2	23.0	5.8
				1700	43.8	3.61	31.5	93.9	3.56	8.8	1700	54.9	36.7	0.67	2.38	63.0	23.0	6.3
	16.0	5.6	12.9	1400	42.8	3.81	29.8	98.3	3.29	9.8	1400	53.7	33.0	0.61	2.28	61.5	23.6	5.4
			1700	71.4	4.15	57.3	108.9	5.04	9.1	1700	55.0	40.4	0.73	3.69	67.6	14.9	6.0	
90	10.0	2.1	5.0	1400	40.1	3.74	27.3	96.5	3.14	10.3	1400	52.6	32.6	0.62	2.38	60.7	22.1	8.0
				1700	41.4	3.58	29.2	92.5	3.38	9.5	1700	54.3	36.1	0.67	2.43	62.5	22.4	8.5
	13.0	2.8	6.5	1400	42.6	3.79	29.7	98.2	3.30	10.6	1400	53.2	32.9	0.62	2.33	61.1	22.8	7.5
				1700	44.1	3.60	31.8	94.0	3.59	9.8	1700	54.8	36.6	0.67	2.38	62.9	23.1	8.1
	16.0	5.4	12.5	1400	42.9	3.84	29.8	98.4	3.27	11.0	1400	53.7	33.2	0.62	2.29	61.5	23.4	6.9
			1700	76.3	4.26	61.8	111.6	5.25	10.2	1700	51.7	39.3	0.76	4.03	65.5	12.8	7.7	
100	10.0	2.1	4.8								Operation not recommended							
	13.0	2.7	6.2								1400	53.0	32.9	0.62	2.35	61.0	22.6	10.0
											1700	54.8	36.5	0.67	2.37	62.9	23.1	10.9
	16.0	5.2	12.0								1400	53.7	33.3	0.62	2.31	61.6	23.3	9.3
										1700	48.7	37.9	0.78	4.49	64.0	10.9	10.4	
110	10.0	2.0	4.6								Operation not recommended							
	13.0	2.6	6.0	Operation not recommended							1400	52.9	33.0	0.62	2.36	60.9	22.4	12.7
											1700	54.7	36.4	0.67	2.37	62.8	23.1	13.8
	16.0	5.0	11.6								1400	53.8	33.5	0.62	2.33	61.7	23.1	11.8
										1700	45.6	36.6	0.80	4.94	62.5	9.2	13.1	
120	10.0	1.9	4.4								Operation not recommended							
	13.0	2.5	5.8								1400	53.7	34.0	0.63	2.34	61.7	22.9	15.8
											1700	54.7	36.9	0.67	2.41	62.9	22.7	17.1
	16.0	4.8	11.1								1400	54.2	34.0	0.63	2.27	61.9	23.9	14.6
										1700	42.3	35.3	0.83	5.45	60.9	7.8	16.3	

Performance capacities shown in thousands of Btu/h.

11/11/13

IMPORTANT NOTE: Refer to Notes to Performance Tables for additional information.

WaterFurnace works continually to improve its products. As a result, the design and specifications of each product at the time of order may be changed without notice. Please contact WaterFurnace at 1-888-929-2837 for latest design and specifications. Purchaser's approval of this data set signifies that the equipment is acceptable under the provisions of the job specification. Statements and other information contained herein are not express warranties and do not form the basis of any bargain between the parties, but are merely WaterFurnace's opinion or commendation of its products. The latest version of this document is available at www.waterfurnace.com.

Contractor: _____ P.O.: _____

Engineer: _____

Project Name: _____ Unit Tag: _____

**Synergy3D Residential Series
3-6 Ton 60Hz**



SDV072 High Speed - Performance Data

EWT °F	Flow gpm	WPD		HEATING - EAT 70°F						COOLING - EAT 80/67 °F								
		PSI	FT	Airflow cfm	HC MBtu/h	Power kW	HE MBtu/h	LAT °F	COP	HWC MBtu/h	Airflow cfm	TC MBtu/h	SC MBtu/h	S/T Ratio	Power kW	HR MBtu/h	EER	HWC MBtu/h
20	12.0	4.0	9.2	Operation not recommended														
	15.0	5.9	13.5	Operation not recommended														
	18.0	8.3	19.2	1850	45.2	4.40	30.2	92.6	3.01	7.9	Operation not recommended							
				2200	46.9	4.68	30.9	89.7	2.93	7.1								
30	12.0	3.9	8.9	Operation not recommended														
				Operation not recommended														
	15.0	5.7	13.1	1850	52.3	4.56	36.7	96.2	3.36	8.3	1850	68.5	44.5	0.65	3.92	81.8	17.5	-
				2200	54.1	4.85	37.6	92.8	3.27	7.6	2200	69.6	48.6	0.70	4.13	83.6	16.9	-
	18.0	8.1	18.6	1850	52.7	4.60	37.0	96.4	3.36	8.5	1850	68.8	44.5	0.65	3.80	81.8	18.1	-
				2200	54.7	4.90	37.9	93.0	3.27	7.7	2200	70.5	48.6	0.69	3.99	84.1	17.7	-
40	12.0	3.7	8.7	Operation not recommended														
				Operation not recommended														
	15.0	5.5	12.7	1850	60.3	4.86	43.7	100.2	3.64	9.2	1850	72.3	46.7	0.65	4.24	86.8	17.0	-
				2200	62.4	5.09	45.0	96.3	3.59	8.4	2200	73.7	51.0	0.69	4.45	88.8	16.6	-
	18.0	7.8	18.1	1850	61.2	4.92	44.4	100.6	3.65	9.5	1850	72.9	46.7	0.64	4.12	86.9	17.7	-
				2200	63.3	5.14	45.8	96.6	3.61	8.6	2200	74.5	51.0	0.68	4.31	89.2	17.3	-
50	12.0	3.6	8.4	1850	64.8	5.07	47.5	102.4	3.75	9.9	1850	75.4	48.2	0.64	4.51	90.8	16.7	4.3
				2200	67.0	5.25	49.1	98.2	3.74	9.2	2200	77.0	52.3	0.68	4.79	93.3	16.1	4.5
	15.0	5.3	12.3	1850	68.4	5.16	50.8	104.2	3.88	10.2	1850	76.2	48.7	0.64	4.41	91.3	17.3	4.0
				2200	70.7	5.33	52.5	99.7	3.89	9.4	2200	77.7	52.9	0.68	4.69	93.7	16.6	4.3
	18.0	7.6	17.5	1850	69.6	5.22	51.8	104.9	3.91	10.5	1850	77.0	49.6	0.64	4.34	91.8	17.7	3.7
				2200	71.9	5.38	53.6	100.3	3.92	9.6	2200	78.5	53.4	0.68	4.62	94.3	17.0	4.1
60	12.0	3.5	8.1	1850	72.9	5.43	54.4	106.5	3.94	11.1	1850	74.8	48.6	0.65	4.82	91.2	15.5	5.2
				2200	75.3	5.53	56.4	101.7	3.99	10.3	2200	76.4	52.5	0.69	5.12	93.8	14.9	5.5
	15.0	5.2	11.9	1850	76.2	5.52	57.3	108.1	4.04	11.5	1850	75.5	49.1	0.65	4.72	91.6	16.0	4.9
				2200	78.6	5.61	59.5	103.1	4.11	10.6	2200	77.1	53.1	0.69	5.02	94.2	15.4	5.3
	18.0	7.3	17.0	1850	77.9	5.59	58.8	109.0	4.08	11.8	1850	76.4	49.8	0.65	4.64	92.2	16.5	4.5
				2200	80.4	5.67	61.1	103.9	4.16	10.9	2200	77.9	53.6	0.69	4.94	94.7	15.8	5.0
70	12.0	3.4	7.9	1850	81.1	5.78	61.3	110.6	4.11	12.5	1850	74.1	49.0	0.66	5.13	91.7	14.4	6.6
				2200	83.6	5.82	63.8	105.2	4.21	11.6	2200	75.7	52.7	0.70	5.46	94.3	13.9	6.9
	15.0	5.0	11.6	1850	83.9	5.87	63.9	112.0	4.19	12.9	1850	74.9	49.5	0.66	5.03	92.0	14.9	6.1
				2200	86.6	5.89	66.5	106.4	4.31	11.9	2200	76.4	53.2	0.70	5.34	94.6	14.3	6.6
	18.0	7.1	16.4	1850	86.1	5.95	65.8	113.1	4.24	13.3	1850	75.7	50.1	0.66	4.94	92.5	15.3	5.7
				2200	88.9	5.95	68.6	107.4	4.38	12.3	2200	77.2	53.9	0.70	5.26	95.2	14.7	6.3
80	12.0	3.3	7.6	1850	87.1	6.12	66.2	113.6	4.17	13.9	1850	70.4	47.4	0.67	5.44	89.0	12.9	8.4
				2200	89.9	6.07	69.2	107.8	4.34	12.8	2200	71.9	51.2	0.71	5.79	91.7	12.4	8.9
	15.0	4.8	11.2	1850	89.2	6.20	68.0	114.6	4.22	14.3	1850	71.1	47.8	0.67	5.33	89.3	13.3	7.8
				2200	92.0	6.12	71.1	108.7	4.41	13.2	2200	72.6	51.7	0.71	5.67	91.9	12.8	8.4
	18.0	6.9	15.9	1850	91.9	6.28	70.5	116.0	4.29	14.7	1850	71.9	48.5	0.68	5.24	89.8	13.7	7.2
				2200	94.9	6.18	73.8	110.0	4.50	13.6	2200	73.4	52.2	0.71	5.58	92.4	13.1	8.0
90	12.0	3.2	7.3	1850	93.1	6.45	71.1	116.6	4.23	15.4	1850	66.7	45.7	0.68	5.75	86.4	11.6	10.5
				2200	96.2	6.32	74.6	110.5	4.46	14.3	2200	68.1	49.6	0.73	6.12	89.0	11.1	11.1
	15.0	4.7	10.8	1850	94.4	6.52	72.2	117.3	4.25	15.9	1850	67.4	46.1	0.68	5.63	86.6	12.0	9.8
				2200	97.5	6.35	75.8	111.0	4.50	14.7	2200	68.8	50.1	0.73	6.00	89.2	11.5	10.6
	18.0	6.6	15.3	1850	97.7	6.61	75.1	118.9	4.33	16.4	1850	68.1	47.0	0.69	5.54	87.0	12.3	9.1
				2200	100.9	6.42	79.0	112.5	4.61	15.2	2200	69.5	50.6	0.73	5.90	89.6	11.8	10.1
100	12.0	3.1	7.1	Operation not recommended														
	15.0	4.5	10.4	1850	63.3	44.8	0.71	6.10	84.1	10.4	12.2							
				2200	64.6	48.4	0.75	6.49	86.8	10.0	13.2							
	18.0	6.4	14.7	1850	64.0	45.4	0.71	6.00	84.5	10.7	11.3							
2200				65.3	48.9	0.75	6.38	87.1	10.2	12.5								
110	12.0	2.9	6.8	Operation not recommended														
	15.0	4.3	10.0	Operation not recommended														
				1850	59.3	43.4	0.73	6.56	81.7	9.0	14.9							
	2200	60.5	46.7	0.77	6.98	84.4	8.7	16.1										
18.0	6.1	14.2	1850	60.0	43.8	0.73	6.45	82.0	9.3	13.8								
			2200	61.2	47.1	0.77	6.86	84.6	8.9	15.3								
120	12.0	2.8	6.5	Operation not recommended														
	15.0	4.2	9.6	Operation not recommended														
				1850	55.3	41.7	0.75	7.45	80.7	7.4	18.0							
	2200	56.3	45.3	0.80	7.65	82.4	7.4	19.5										
18.0	5.9	13.6	1850	55.8	41.7	0.75	7.21	80.4	7.7	16.7								
			2200	57.0	45.3	0.79	7.44	82.4	7.7	18.5								

Performance capacities shown in thousands of Btu/h.

11/11/13

IMPORTANT NOTE: Refer to Notes to Performance Tables for additional information.

WaterFurnace works continually to improve its products. As a result, the design and specifications of each product at the time of order may be changed without notice. Please contact WaterFurnace at 1-888-929-2837 for latest design and specifications. Purchaser's approval of this data set signifies that the equipment is acceptable under the provisions of the job specification. Statements and other information contained herein are not express warranties and do not form the basis of any bargain between the parties, but are merely WaterFurnace's opinion or commendation of its products. The latest version of this document is available at www.waterfurnace.com.



Contractor: _____ P.O.: _____

Engineer: _____

Project Name: _____ Unit Tag: _____

SDV072 Water Heating Data

ELT	EST	LGPM	SOURCE 12.0 GPM							SWPD		HWC MBtuh	SOURCE 15.0 GPM							SWPD		HWC MBtuh	SOURCE 18.0 GPM							SWPD		HWC MBtuh
			LLT	HC	KW	HE	COP	LST	PSI	FT HD	LLT		HC	KW	HE	COP	LST	PSI	FT HD	LLT	HC		KW	HE	COP	LST	PSI	FT HD				
80	30	12.0	Operation Not Recommended																													
		15.0	87.3	52.9	4.07	39.0	3.8	23.3	4.0	9.2	7.7	87.5	53.8	4.08	39.9	3.9	24.3	6.2	14.2	7.9	87.6	54.7	4.10	40.7	3.9	25.3	8.3	19.2	8.1			
		18.0	85.9	52.9	4.03	39.1	3.8	23.3	4.0	9.2	7.4	86.0	53.8	4.04	40.0	3.9	24.3	6.2	14.2	7.6	86.1	54.7	4.05	40.9	4.0	25.3	8.3	19.2	7.7			
80	40	12.0	Operation Not Recommended																													
		15.0	88.6	61.8	4.20	47.4	4.3	31.9	3.9	9.0	8.6	88.7	63.0	4.22	48.6	4.4	33.1	6.0	13.8	8.8	88.9	64.2	4.24	49.7	4.4	34.5	8.1	18.6	9.0			
		18.0	86.9	61.8	4.16	47.6	4.4	31.8	3.9	9.0	8.3	87.0	63.0	4.17	48.7	4.4	33.1	6.0	13.8	8.5	87.1	64.2	4.19	49.9	4.5	34.5	8.1	18.6	8.6			
80	50	12.0	91.8	70.7	4.38	55.7	4.7	40.4	3.8	8.7	10.0	92.0	72.2	4.41	57.1	4.8	42.0	5.8	13.3	10.2	92.3	73.7	4.44	58.6	4.9	43.5	7.8	18.0	10.4			
		15.0	89.8	70.6	4.33	55.9	4.8	40.4	3.8	8.7	9.6	90.0	72.2	4.36	57.3	4.9	41.9	5.8	13.3	9.8	90.2	73.7	4.39	58.7	4.9	43.5	7.8	18.0	10.0			
		18.0	87.8	70.6	4.28	56.0	4.8	40.4	3.8	8.7	9.2	88.0	72.2	4.31	57.5	4.9	41.9	5.8	13.3	9.4	88.2	73.7	4.33	58.9	5.0	43.5	7.8	18.0	9.6			
80	60	12.0	93.3	79.5	4.52	64.1	5.2	49.0	3.6	8.4	11.3	93.6	81.4	4.55	65.8	5.2	50.7	5.6	12.9	11.5	93.9	83.2	4.59	67.6	5.3	52.5	7.6	17.4	11.7			
		15.0	91.0	79.5	4.46	64.3	5.2	49.0	3.6	8.4	10.8	91.3	81.3	4.49	66.0	5.3	50.7	5.6	12.9	11.1	91.6	83.2	4.53	67.7	5.4	52.5	7.6	17.4	11.3			
		18.0	88.8	79.5	4.40	64.5	5.3	48.9	3.6	8.4	10.4	89.0	81.3	4.44	66.2	5.4	50.7	5.6	12.9	10.6	89.2	83.1	4.47	67.9	5.4	52.5	7.6	17.4	10.9			
80	70	12.0	94.7	88.4	4.65	72.6	5.6	57.5	3.5	8.1	12.7	95.1	90.6	4.69	74.6	5.7	59.5	5.4	12.5	13.0	95.5	92.7	4.73	76.5	5.7	61.5	7.3	16.9	13.2			
		15.0	92.3	88.4	4.59	72.7	5.6	57.5	3.5	8.1	12.2	92.6	90.5	4.63	74.7	5.7	59.5	5.4	12.5	12.5	92.9	92.7	4.67	76.7	5.8	61.5	7.3	16.9	12.7			
		18.0	89.8	88.4	4.53	72.9	5.7	57.5	3.5	8.1	11.8	90.1	90.5	4.57	74.9	5.8	59.5	5.4	12.5	12.0	90.3	92.6	4.61	76.9	5.9	61.5	7.3	16.9	12.3			
100	30	12.0	Operation Not Recommended																													
		15.0	107.1	51.1	5.13	33.6	2.9	24.2	4.0	9.2	7.5	107.2	51.8	5.13	34.3	3.0	25.2	6.2	14.2	7.6	107.3	52.6	5.13	35.0	3.0	26.1	8.3	19.2	7.7			
		18.0	105.7	51.1	5.08	33.7	2.9	24.2	4.0	9.2	7.2	105.8	51.8	5.08	34.4	3.0	25.1	6.2	14.2	7.3	105.8	52.5	5.09	35.2	3.0	26.1	8.3	19.2	7.4			
100	40	12.0	Operation Not Recommended																													
		15.0	108.2	59.2	5.24	41.4	3.3	32.9	3.9	9.0	8.3	108.4	60.2	5.25	42.3	3.4	34.0	6.0	13.8	8.4	108.5	61.2	5.26	43.2	3.4	35.2	8.1	18.6	8.5			
		18.0	106.6	59.2	5.18	41.5	3.3	32.9	3.9	9.0	7.9	106.7	60.2	5.19	42.5	3.4	34.0	6.0	13.8	8.1	106.8	61.2	5.21	43.4	3.4	35.2	8.1	18.6	8.2			
100	50	12.0	111.2	67.4	5.41	48.9	3.6	41.6	3.8	8.7	9.5	111.4	68.6	5.43	50.0	3.7	43.0	5.8	13.3	9.7	111.6	69.8	5.45	51.2	3.8	44.3	7.8	18.0	9.8			
		15.0	109.4	67.4	5.35	49.1	3.7	41.6	3.8	8.7	9.2	109.5	68.6	5.37	50.3	3.7	42.9	5.8	13.3	9.3	109.7	69.8	5.39	51.4	3.8	44.3	7.8	18.0	9.5			
		18.0	107.5	67.4	5.29	49.3	3.7	41.5	3.8	8.7	8.8	107.6	68.6	5.30	50.5	3.8	42.9	5.8	13.3	9.0	107.8	69.8	5.32	51.7	3.8	44.3	7.8	18.0	9.1			
100	60	12.0	112.6	75.5	5.53	56.6	4.0	50.3	3.6	8.4	10.7	112.8	77.0	5.56	58.0	4.1	51.8	5.6	12.9	10.9	113.1	78.4	5.59	59.3	4.1	53.4	7.6	17.4	11.0			
		15.0	110.5	75.5	5.46	56.9	4.1	50.2	3.6	8.4	10.3	110.7	77.0	5.49	58.2	4.1	51.8	5.6	12.9	10.5	110.9	78.4	5.51	59.6	4.2	53.4	7.6	17.4	10.6			
		18.0	108.4	75.5	5.39	57.1	4.1	50.2	3.6	8.4	9.9	108.6	77.0	5.42	58.5	4.2	51.8	5.6	12.9	10.1	108.7	78.5	5.44	59.9	4.2	53.3	7.6	17.4	10.2			
100	70	12.0	113.9	83.7	5.65	64.4	4.3	58.9	3.5	8.1	12.0	114.2	85.3	5.69	65.9	4.4	60.7	5.4	12.5	12.2	114.5	87.0	5.72	67.5	4.5	62.5	7.3	16.9	12.4			
		15.0	111.6	83.7	5.57	64.6	4.4	58.9	3.5	8.1	11.6	111.9	85.4	5.61	66.2	4.5	60.7	5.4	12.5	11.8	112.1	87.1	5.64	67.8	4.5	62.5	7.3	16.9	12.0			
		18.0	109.3	83.7	5.50	64.9	4.5	58.8	3.5	8.1	11.1	109.5	85.4	5.53	66.5	4.5	60.6	5.4	12.5	11.3	109.7	87.1	5.56	68.2	4.6	62.4	7.3	16.9	11.5			
120	30	12.0	Operation Not Recommended																													
		15.0	126.9	49.3	6.18	28.2	2.3	25.2	4.0	9.2	7.2	126.9	49.8	6.18	28.8	2.4	25.9	6.2	14.2	7.3	127.0	50.4	6.17	29.3	2.4	26.6	8.3	19.2	7.4			
		18.0	125.5	49.2	6.12	28.3	2.4	25.1	4.0	9.2	6.9	125.5	49.8	6.12	28.9	2.4	25.9	6.2	14.2	7.0	125.6	50.3	6.13	29.4	2.4	26.6	8.3	19.2	7.1			
120	40	12.0	Operation Not Recommended																													
		15.0	127.9	56.7	6.27	35.3	2.6	33.9	3.9	9.0	7.9	128.0	57.4	6.28	36.0	2.7	34.9	6.0	13.8	8.0	128.1	58.2	6.28	36.7	2.7	35.9	8.1	18.6	8.1			
		18.0	126.3	56.6	6.21	35.5	2.7	33.9	3.9	9.0	7.6	126.4	57.4	6.21	36.2	2.7	34.9	6.0	13.8	7.7	126.5	58.2	6.22	36.9	2.7	35.9	8.1	18.6	7.8			
120	50	12.0	130.7	64.1	6.44	42.1	2.9	42.8	3.8	8.7	9.1	130.8	65.0	6.45	43.0	3.0	43.9	5.8	13.3	9.2	131.0	65.9	6.46	43.8	3.0	45.1	7.8	18.0	9.3			
		15.0	128.9	64.1	6.37	42.4	2.9	42.7	3.8	8.7	8.7	129.0	65.0	6.38	43.3	3.0	43.9	5.8	13.3	8.8	129.2	65.9	6.39	44.1	3.0	45.1	7.8	18.0	8.9			
		18.0	127.1	64.1	6.29	42.6	3.0	42.7	3.8	8.7	8.4	127.2	65.0	6.30	43.5	3.0	43.9	5.8	13.3	8.5	127.3	66.0	6.31	44.4	3.1	45.1	7.8	18.0	8.6			
120	60	12.0	131.9	71.5	6.55	49.1	3.2	51.6	3.6	8.4	10.1	132.1	72.5	6.57	50.1	3.2	52.9	5.6	12.9	10.2	132.3	73.6	6.58	51.1	3.3	54.3	7.6	17.4	10.4			
		15.0	129.9	71.5	6.46	49.5	3.2	51.5	3.6	8.4	9.7	130.1	72.6	6.48	50.5	3.3	52.8	5.6	12.9	9.9	130.2	73.7	6.50	51.5	3.3	54.3	7.6	17.4	10.0			
		18.0	127.9	71.5	6.38	49.8	3.3	51.5	3.6	8.4	9.4	128.1	72.7	6.39	50.9	3.3	52.8	5.6	12.9	9.5	128.2	73.8	6.41	52.0	3.4	54.2	7.6	17.4	9.6			
120	70	12.0	133.1	78.9	6.65	56.2	3.5	60.4	3.5	8.1	11.3	133.3	80.1	6.68	57.3	3.5	61.8	5.4	12.5	11.5	133.5	81.3	6.71	58.4	3.6	63.3	7.3	16.9	11.6			
		15.0	131.0	78.9	6.56	56.5	3.5	60.3	3.5	8.1	10.9	131.1	80.2	6.58	57.7	3.6	61.8	5.4	12.5	11.1	131.3	81.5	6.60	58.9	3.6	63.2	7.3	16.9	11.2			
		18.0	128.8	79.0	6.47	56.9	3.6	60.2	3.5	8.1	10.5	128.9	80.3	6.48	58.2	3.6	61.7	5.4	12.5	10.7	129.1	81.7	6.50	59.5	3.7	63.2	7.3	16.9	10.8			

* Water heating mode only allows high compressor capacity operation.

2/21/11

ELT = entering load fluid temperature to heat pump
LLT = leaving load fluid temperature from heat pump
LGPM = load flow in gallons per minute
LWPD = load coax water pressure drop
EST = entering source fluid temperature to heat pump
LST = leaving source fluid temperature from heat pump
HWC = hot water generator capacity

SWPD = source coax water pressure drop
PSI = pressure drop in pounds per square inch
FT HD = pressure drop in feet of head
KW = kilowatts
HE = heat extracted in Btuh
HC = total heating capacity in Btuh
COP = coefficient of performance [HC/(kW x 3.413)]

IMPORTANT NOTE: Refer to Notes to Performance Tables for additional information.

Contractor: _____ P.O.: _____
 Engineer: _____
 Project Name: _____ Unit Tag: _____

**Synergy3D Residential Series
 3-6 Ton 60Hz**



Wiring Schematics

208-230/60/1 ECM

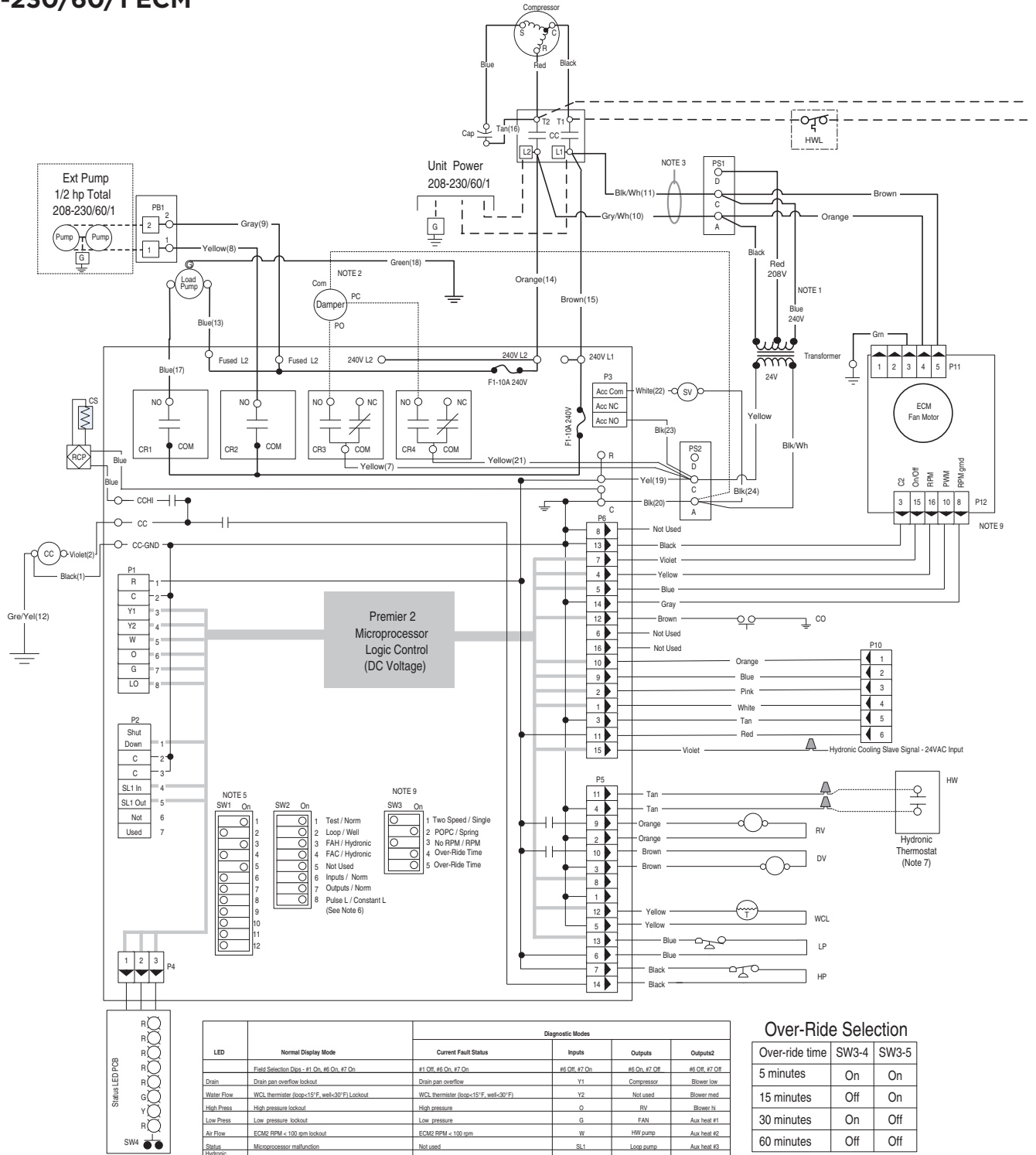

LED	Normal Display Mode	Diagnostic Modes			
		Current Fault Status	Inputs	Outputs	Output2
	Field Selection Dies - #1 On, #6 On, #7 On	#1 Off, #6 On, #7 On	#8 Off, #7 On	#6 On, #7 Off	#5 Off, #7 Off
Drain	Drain pan overflow lockout	Drain pan overflow	Y1	Compressor	Blower low
Water Flow	WCL thermostat (loop<15°F, well>30°F) Lockout	WCL thermostat (loop<15°F, well>30°F)	Y2	Not used	Blower med
High Press	High pressure lockout	High pressure	C	RV	Blower hi
Low Press	Low pressure lockout	Low pressure	G	FAN	Aux heat #1
Air Flow	ECM2 RPM < 100 rpm lockout	ECM2 RPM < 100 rpm	W	HW pump	Aux heat #2
Status	Microprocessor malfunction	Not used	SL1	Loop pump	Aux heat #3
Hydronic Hi Limit	Not used	Not used	HW	DV	Aux heat #4
Hydronic Off	Hot-water disable	HW off	HW off	HW off	HW off

Over-Ride Selection

Over-ride time	SW3-4	SW3-5
5 minutes	On	On
15 minutes	Off	On
30 minutes	On	Off
60 minutes	Off	Off

WaterFurnace works continually to improve its products. As a result, the design and specifications of each product at the time of order may be changed without notice. Please contact WaterFurnace at 1-888-929-2837 for latest design and specifications. Purchaser's approval of this data set signifies that the equipment is acceptable under the provisions of the job specification. Statements and other information contained herein are not express warranties and do not form the basis of any bargain between the parties, but are merely WaterFurnace's opinion or commendation of its products. The latest version of this document is available at www.waterfurnace.com.

Contractor: _____ P.O.: _____

Engineer: _____

Project Name: _____ Unit Tag: _____

**Synergy3D Residential Series
3-6 Ton 60Hz**



Wiring Schematics cont.

208-230/60/1 ECM cont.

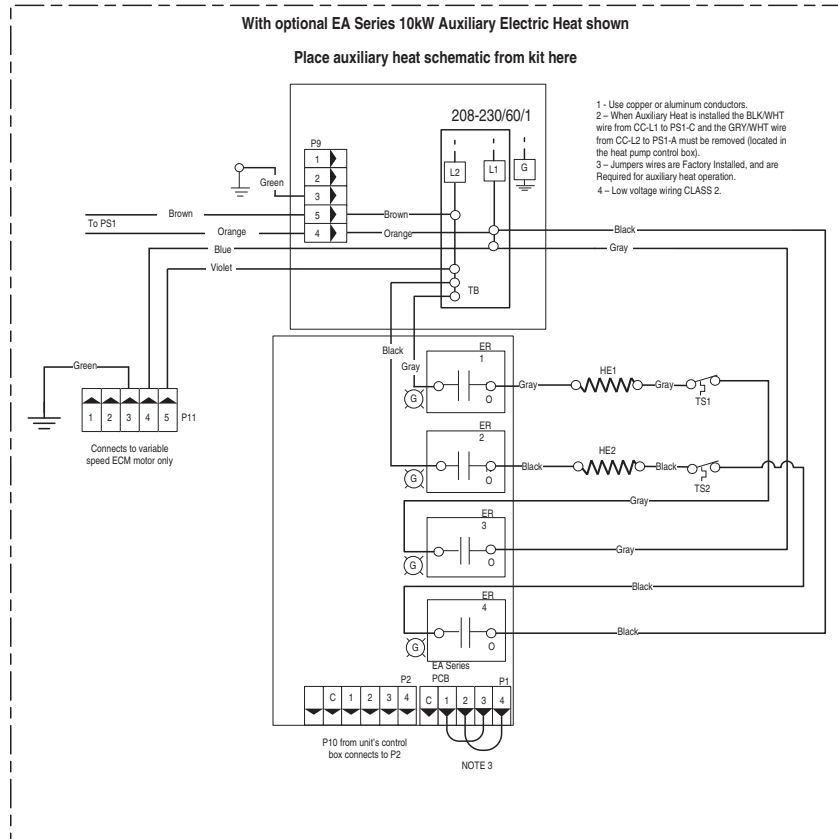
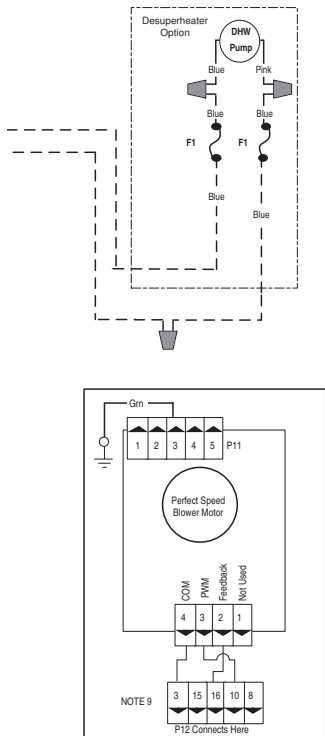

Legend

CC - Compressor Contactor
 CO - Condensate overflow sensor
 CR1 - DHW pump relay
 CR2 - Loop pump relay
 CR3 - PSC Fan Speed Relay
 CR4 - PSC Fan Power Relay
 CS - Compressor Solenoid
 F1 and F2 - Fuses
 HE - Heater element
 HP - High pressure switch
 ER1 to ER4 - Aux heat stage relays
 LP - Low pressure switch
 PB1, PB2 - Power blocks
 PR - Pump Relay
 PS - Power strip
 RV - Reversing Valve coil
 SW1 - DIP package 12 position
 SW2 - DIP package 8 position
 SW3 - DIP package 5 position
 SW4 - Hot water pump enable switch
 TS - Thermal limit switch
 HWL - Hot water limit sensor
 WCL - Water Coil Limit Sensor

Operation Logic Data

Operation Logic Table	Heating				Cooling		Hot Water Mode
	STG1	STG2	STG3	EMERG	STG1	STG2	
Compressor	On	On	On	Off	On	On	Stg 2 On
Reversing Valve	Off	Off	Off	Off	On	On	Off
Loop Pump	On	On	On	Off	On	On	On
Load Pump	Off	Off	Off	Off	Off	Off	On
Aux Heater	Off	Off	Staged	Staged	Off	Off	Off
Acc Relay	On	On	On	On	On	On	Off
Diverting Valve	Off	Off	Off	Off	Off	Off	On
ECM Speed	On	On	On	On	On	On	Off
T-Stat Signal	Y1	Y1, Y2	Y1, Y2, W	W	Y1, O	Y1, Y2, O	HW
Damper	Off	Off	Off	On	Off	Off	Off
Auxiliary 1 - Out	On	On	On	Off	On	On	On

Notes

- Switch blue and red wires for 208V operation.
- Typical hook-up shown for power open - power closed damper shown.
- The blk/wh and gray/wh wires are removed when Aux Heat is installed.
- Use part number 19P592-01 (jumper bar assembly) when single source power is required.
- Air Flow Configuration Example: SW1 configured for dip 1 as low, dip 3 as medium, and dip 5 as high speed ECM fan.
- SW2-8 must be in the OFF position for pulsed "L" lockout signal and in the ON position for constant "L" lockout signal.
- A hydronic input will generate a Y2 compressor call so that compressor only operates in high capacity.
- Low voltage wiring CLASS 2.
- On units with a Perfect Speed ECM blower motors, the blower's low voltage harness from the board with the P12 connector will connect to a jumper harness that is connected to the blower motor. SW3-3 DIP switch should be set in the OFF position.

WaterFurnace works continually to improve its products. As a result, the design and specifications of each product at the time of order may be changed without notice. Please contact WaterFurnace at 1-888-929-2837 for latest design and specifications. Purchaser's approval of this data set signifies that the equipment is acceptable under the provisions of the job specification. Statements and other information contained herein are not express warranties and do not form the basis of any bargain between the parties, but are merely WaterFurnace's opinion or commendation of its products. The latest version of this document is available at www.waterfurnace.com.

Contractor: _____ P.O.: _____
 Engineer: _____
 Project Name: _____ Unit Tag: _____

**Synergy3D Residential Series
 3-6 Ton 60Hz**



Wiring Schematics cont.

208-230/60/1 ECM with IntelliStart

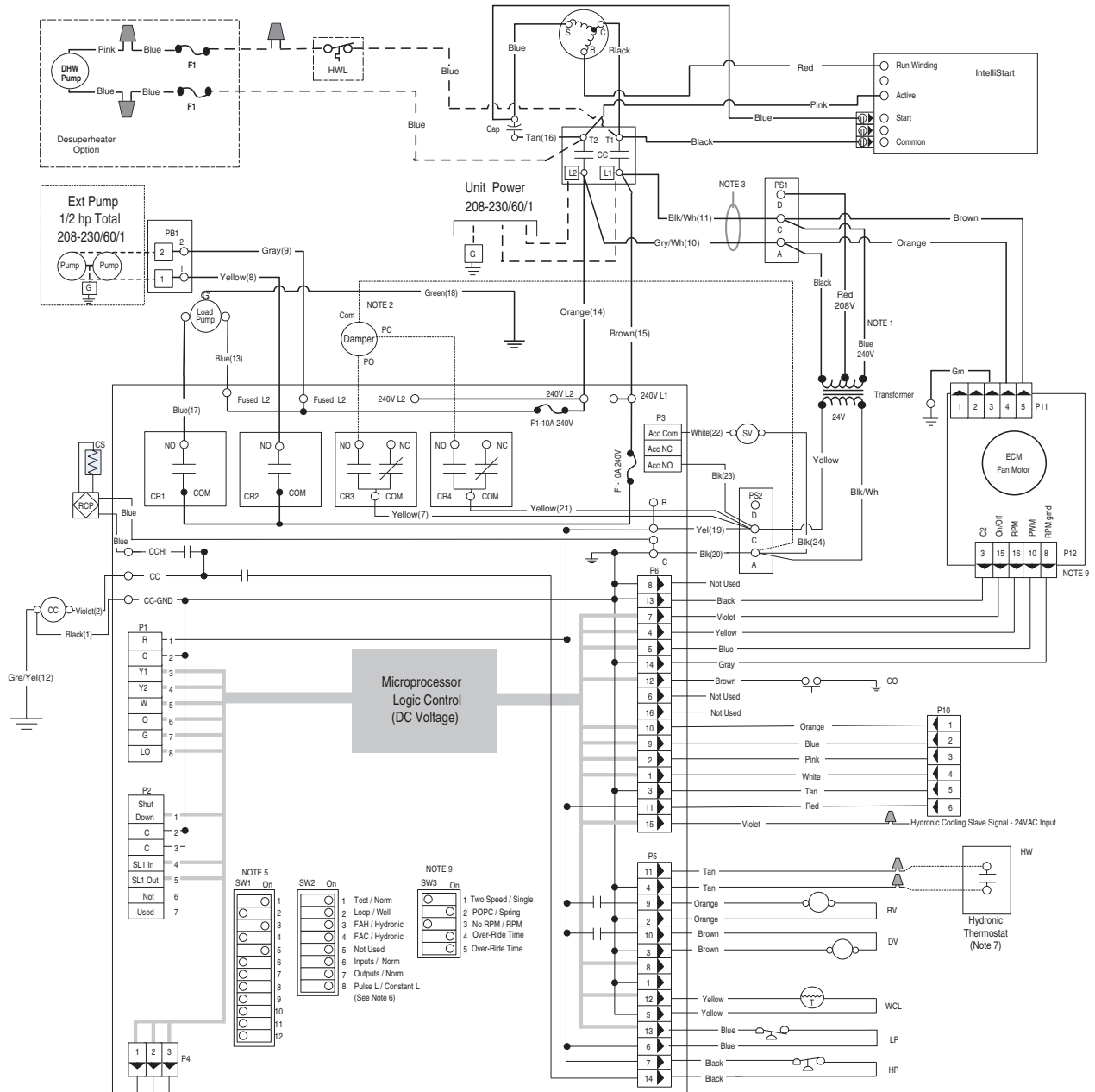

LED	Normal Display Mode	Diagnostic Modes			
		Current Fault Status	Inputs	Outputs	Output2
	Field Selection Des - #1 On, #6 On, #7 On	#1 Off, #6 On, #7 On	#5 Off, #7 On	#5 On, #7 Off	#5 Off, #7 Off
Drain	Drain pan overflow lockout	Drain pan overflow	Y1	Compressor	Blower low
Water Flow	WCL thermostat (loop-19°F, well<30°F) Lockout	WCL thermostat (loop-19°F, well<30°F)	Y2	Not used	Blower med
High Press	High pressure lockout	High pressure	D	FAN	Blower hi
Low Press	Low pressure lockout	Low pressure	G	RV	Aux heat #1
Air Flow	ECM2 RPM < 100 rpm lockout	ECM2 RPM < 100 rpm	W	HW pump	Aux heat #2
Status	Microprocessor malfunction	Not used	SL1	Loop pump	Aux heat #3
Hydronic	Not used	Not used	HW	DV	Aux heat #4
Hydronic Off	Hot-water disable	HW off	HW off	HW off	HW off

Over-Ride Selection

Over-ride time	SW3-4	SW3-5
5 minutes	On	On
15 minutes	Off	On
30 minutes	On	Off
60 minutes	Off	Off

WaterFurnace works continually to improve its products. As a result, the design and specifications of each product at the time of order may be changed without notice. Please contact WaterFurnace at 1-888-929-2837 for latest design and specifications. Purchaser's approval of this data set signifies that the equipment is acceptable under the provisions of the job specification. Statements and other information contained herein are not express warranties and do not form the basis of any bargain between the parties, but are merely WaterFurnace's opinion or commendation of its products. The latest version of this document is available at www.waterfurnace.com.

Contractor: _____ P.O.: _____
 Engineer: _____
 Project Name: _____ Unit Tag: _____

**Synergy3D Residential Series
 3-6 Ton 60Hz**



Wiring Schematics cont.

208-230/60/1 ECM with IntelliStart cont.

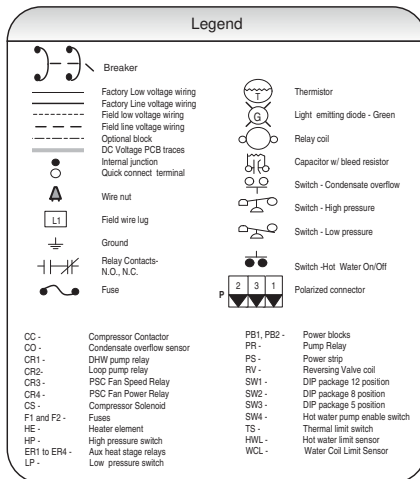
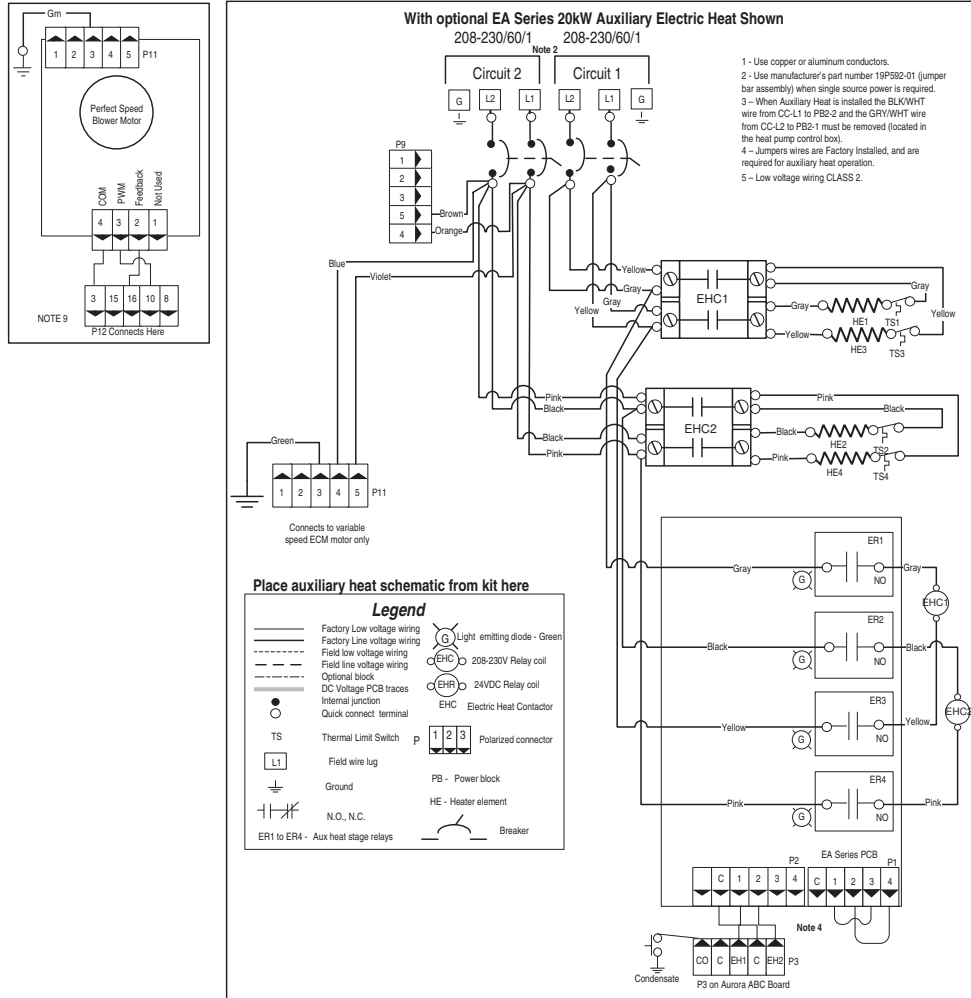

Operation Logic Data

Operation Logic Table	Heating				Cooling		Hot Water Mode
	STG1	STG2	STG3	EMERG	STG1	STG2	
Compressor	On	On	Off	Off	On	On	Stg 2 On
Reversing Valve	Off	Off	Off	Off	On	On	Off
Loop Pump	On	On	On	Off	On	On	On
Load Pump	Off	Off	Off	Off	Off	Off	On
Aux Heater	Off	Off	Staged	Staged	Off	Off	Off
Acc Relay	On	On	On	Off	On	On	Off
Diverting Valve	Off	Off	Off	Off	Off	Off	On
ECM Speed	On	On	On	On	On	On	Off
T-Stat Signal	Y1	Y1, Y2	Y1, Y2, W	W	Y1, O	Y1, Y2, O	HW
Damper	Off	Off	Off	On	Off	Off	Off
Auxiliary 1 - Out	On	On	On	Off	On	On	On

- Notes**
- Switch blue and red wires for 208V operation.
 - Typical hook-up shown for power open - power closed damper shown.
 - The blk/wh and gray/wh wires are removed when Aux Heat is installed.
 - Use part number 19P592-01 (jumper bar assembly) when single source power is required.
 - Air Flow Configuration Example: SW1 configured for dip 1 as low, dip 3 as medium, and dip 5 as high speed ECM fan.
 - SW2-8 must be in the OFF position for pulsed "L" lockout signal and in the ON position for constant "L" lockout signal.
 - A hydronic input will generate a Y2 compressor call so that compressor only operates in high capacity.
 - Low voltage wiring CLASS 2.
 - On units with a Perfect Speed ECM blower motors, the blower's low voltage harness from the board with the P12 connector will connect to a jumper harness that is connected to the blower motor. SW3-3 DIP switch should be set in the OFF position.

WaterFurnace works continually to improve its products. As a result, the design and specifications of each product at the time of order may be changed without notice. Please contact WaterFurnace at 1-888-929-2837 for latest design and specifications. Purchaser's approval of this data set signifies that the equipment is acceptable under the provisions of the job specification. Statements and other information contained herein are not express warranties and do not form the basis of any bargain between the parties, but are merely WaterFurnace's opinion or commendation of its products. The latest version of this document is available at www.waterfurnace.com.



Contractor: _____ P.O.: _____

Engineer: _____

Project Name: _____ Unit Tag: _____

Engineering Guide Specifications

General

Synergy3D units shall be floor mounted type with horizontal air inlet and vertical up flow or rear air discharge. Reverse cycle operation shall provide heating or cooling in the forced air mode. The unit shall also be capable of heating water for hydronic applications when the unit is not in the forced air mode. Units shall be AHRI/ISO Standard 13256-1 performance certified and listed by a nationally recognized safety-testing laboratory or agency, such as ETL Testing Laboratory. Each unit shall be computer run-tested at the factory. Each unit shall be mounted on a pallet for shipping.

The geothermal units shall be designed to operate with entering liquid temperature between 20°F and 120°F [-6.7°C - 48.9°C].

Refrigerant Circuit

All units shall contain a sealed refrigerant circuit including: a hermetic motor-compressor, discharge muffler, bidirectional thermal expansion valve, finned tube air-to-refrigerant heat exchanger, solenoid valve, diverting valve, check valve, reversing valve, source coaxial tube water-to-refrigerant heat exchanger, load coaxial tube refrigerant-to-water heat exchanger, optional hot water generator coil, and service ports.

Compressors shall be high efficiency dual capacity scroll type designed for heat pump duty and mounted on vibration isolators. Compressor motors shall be single-phase PSC with overload protection. The finned tube air-to-refrigerant heat exchanger will be aluminum tube/fin and shall be sized for low-face velocity and constructed of lanced aluminum fins bonded to performance enhanced tubes in a staggered pattern not less than three rows deep for superior performance. The aluminum tube and fin air-to-refrigerant heat exchanger has as optional to be electro-coated with AlumiSeal. All models shall include discharge line mufflers to help quiet compressor discharge gas pulsations.

All units shall have the source coaxial tube refrigerant-to-water heat exchanger and optional hot water generator ThermaShield coated.

Casing and Cabinet

The cabinet shall be fabricated from heavy-gauge galvanized steel and finished with corrosion-resistant powder coating. This corrosion protection system shall meet the stringent 1000 hour salt spray test per ASTM B117. The interior shall be insulated with 1/2-inch thick, multi-density, cleanable aluminum foil coated glass fiber with edges sealed or tucked under flanges to prevent

the introduction of glass fibers into the discharge air. Standard cabinet panel insulation must meet NFPA 90A requirements, air erosion and mold growth limits of UL-181, stringent fungal resistance test per ASTM-C1071 and ASTM G21, and shall meet zero level bacteria growth per ASTM G22. Unit insulation must meet these stringent requirements or unit(s) will not be accepted.

Two blower and three compressor compartment access panels shall be 'lift-out' removable with supply and return ductwork in place. The control box shall be hinged and removable to allow easy access to the compressor. The internal component layout shall provide for service access from the front side for restricted installations.

A duct collar shall be provided on the supply air opening. Standard size 2 in. [5.1 cm] MERV 11 pleated filters shall be provided with each unit. Vertical units shall have a return air filter rack/duct collar. The upflow vertical units shall have a removable insulated divider panel between the air handling section and the compressor section to minimize the transmission of compressor noise and to permit operational service testing without air bypass. Vertical units shall be supplied with left or right horizontal air inlet and top vertical or rear air discharge.

The compressor shall be double isolation mounted using selected durometer grommets to provide vibration free compressor mounting.

The drain pan shall be of plastic construction to inhibit corrosion and bacterial growth. Drain outlet shall be located on pan as to allow complete and unobstructed drainage of condensate. The unit as standard will be supplied with solid-state electronic condensate overflow protection. Mechanical float switches WILL NOT be accepted. Vertical units shall be furnished with a PVC slip condensate drain connection and an internal factory installed condensate trap.

Blower Motor and Assembly

The blower shall be a direct drive centrifugal type with a dynamically balanced wheel. The housing and wheel shall be designed for quiet low outlet velocity operation. Tight blower housing geometry shall not be permitted. The blower housing shall be removable from the unit without disconnecting the supply air ductwork for servicing of the blower motor. The blower motor shall be a variable speed ECM type. The variable speed ECM blower motor shall be soft starting, shall maintain constant CFM over its operating static range, and shall provide 12 CFM settings. The blower motor shall be isolated from the housing by rubber grommets. The motor shall be permanently lubricated and have thermal overload protection. Variable speed ECM motors shall be long-life ball bearing type.

WaterFurnace works continually to improve its products. As a result, the design and specifications of each product at the time of order may be changed without notice. Please contact WaterFurnace at 1-888-929-2837 for latest design and specifications. Purchaser's approval of this data set signifies that the equipment is acceptable under the provisions of the job specification. Statements and other information contained herein are not express warranties and do not form the basis of any bargain between the parties, but are merely WaterFurnace's opinion or commendation of its products. The latest version of this document is available at www.waterfurnace.com.



Contractor: _____ P.O.: _____

Engineer: _____

Project Name: _____ Unit Tag: _____

Engineering Guide Specifications cont.

Electrical

A control box shall be located within the unit compressor compartment and shall contain a 75VA transformer, 24 volt activated, 2 pole compressor contactor, terminal block for thermostat wiring and solid-state controller for complete unit operation. Electromechanical operation WILL NOT be accepted. Units shall be name-plated for use with time delay fuses or HACR circuit breakers. Unit controls shall be 24 volt and provide heating or cooling as required by the remote thermostat/sensor. The controller shall also be capable of operating the unit in a hydronic heating mode with input from an external thermostat. A microprocessor-based controller that interfaces with a multi-stage electronic thermostat to monitor and control unit operation shall be provided. The control shall provide operational sequencing, blower speed control, blower failure, high and low pressure switch monitoring, freeze detection sensor temperature limit, condensate overflow sensing, auxiliary heat staging, lockout mode control, load pump and loop pump control, LED status and fault indicators, fault memory, field selectable options, and accessory output.

A detachable terminal block with screw terminals will be provided for field control wiring. All units shall have knockouts for entrance of low and line voltage wiring. The blower motor and control box shall be harness plug wired for easy removal.

Optional IntelliStart (Compressor Soft Starter) - shall be factory installed for use in applications that require low starting amps, reduced compressor startup noise, off-grid, and improved start-up behavior. IntelliStart shall reduce normal starting current by 60% on 208-230/60/1 units.

Piping

Source and load supply and return water connections shall be 1 in. [25.4 mm] FPT brass swivel fittings, which provide a union and eliminate the need for pipe wrenches and sealants when making field connections. The optional hot water generator shall have sweat type connections. All water piping shall be insulated to prevent condensation at low liquid temperatures. On the vertical upflow units, the condensate connection shall be a 3/4 in. [19.1 mm] PVC socket with internally-trapped hose that can be routed to front or side locations.

Options and Accessories

Cupronickel Heat Exchanger

An optional cupronickel water-to-refrigerant heat exchanger shall be provided.

Hot Water Generator

An optional ThermaShield coated heat reclaiming hot water generator coil of vented double-wall copper construction suitable for potable water shall be provided. The coil shall be factory mounted inside the unit. An internal pump is not included. Order DPK5 for field installed pump and temperature limit.

Thermostat (field-installed)

A multi-stage auto-changeover electronic digital thermostat shall be provided. The thermostat shall offer three heating and two cooling stages with precise temperature control. An OFF-HEAT-AUTO-COOL-EMERG system switch, OFF-AUTO blower switch, and indicating LEDs shall be provided. The thermostat shall display in °F or °C.

Electronic Air Cleaner (field-installed)

A 1 in. [25 mm] electronic air cleaner, cleanable 97% efficiency at 0.3 microns and larger, shall be provided in lieu of the standard throwaway filter. The initial pressure drop across the filter shall not exceed 0.2 in. w.g. at 300 fpm face velocity.

Electrostatic Air Cleaner (field-installed)

A 1 in. [25 mm] electrostatic air cleaner, cleanable 90% efficiency, shall be provided in lieu of the standard throwaway filter. The initial pressure drop across the filter shall not exceed 0.15 in. w.g. at 300 fpm face velocity.

AlpinePure 411-Rack 4 in. Pleated Filter Accessory

A 4 in. thick [102 mm] MERV 11 filter and filter rack shall be provided in lieu of the standard filter and rack.

AlpinePure MERV 13 Filter (field installed)

A 2 in. thick [50 mm] MERV 13 filter shall be provided in lieu of the standard filter and fits the factory filter rack. The filter maintains MERV 13 rating in full ASHRAE 52.2 independent testing as required for LEED® certification. Helps fulfill a full credit under the LEED® rating system.



Contractor: _____ P.O.: _____
Engineer: _____
Project Name: _____ Unit Tag: _____

Engineering Guide Specifications cont.

Earth Loop Flow Center (field-installed)

A self-contained module shall provide all liquid flow, fill and connection requirements for ground source closed loop systems up to 20 GPM. The pumps shall be wired to a power block located in the nearest unit. The heat pump units shall contain low voltage pump slaving control so that two units may share one flow center.

Auxiliary Heater (field-installed)

An electric resistance heater shall provide supplemental and/or emergency heating capability. Vertical units shall have the control box and resistance heater coil assembly mounted internally. A low voltage plug shall be provided in each unit for quick auxiliary heat connection. The heater shall operate in sequenced stages as controlled by the unit's microprocessor. The heater shall feed line voltage power to the unit blower and transformer to provide emergency heat capability in the event of an open compressor circuit breaker.

AlpinePure Drain Pan Treatment

Provides dependable, sustained time-release protection from slime build-up and foul smelling odors in the drain pan. Also adds a light, pleasant scent to the air.

WaterFurnace works continually to improve its products. As a result, the design and specifications of each product at the time of order may be changed without notice. Please contact WaterFurnace at 1-888-929-2837 for latest design and specifications. Purchaser's approval of this data set signifies that the equipment is acceptable under the provisions of the job specification. Statements and other information contained herein are not express warranties and do not form the basis of any bargain between the parties, but are merely WaterFurnace's opinion or commendation of its products. The latest version of this document is available at www.waterfurnace.com.

Contractor: _____ P.O.: _____

Engineer: _____

Project Name: _____ Unit Tag: _____

Synergy3D Residential Series
3-6 Ton 60Hz



Revision Guide

Pages:	Description:	Date:	By:
Misc.	Updated for Aluminum Coils, Wiring Schematics	15 May 2017	JM
26-29	Updated Wiring Schematics for Auxiliary Heat Change	14 April 2015	MA
2	Updated Nomenclature Hot Water Generation Option	30 Sept 2014	MA
All	Updated to new Revision, Reformatted Layout	27 Dec 2013	DS
All	Updated Nomenclature to Reflect new ECM Blower Motor	09 Nov 2012	DS
30	Added Notes Regarding Discharge Muffler	12 Oct 2012	DS
11	Updated Cooling Capacity Corrections	12 Oct 2012	DS
All	Various Formatting Corrections	12 Oct 2012	DS
33	Added Revision Guide	12 Oct 2012	DS

WaterFurnace works continually to improve its products. As a result, the design and specifications of each product at the time of order may be changed without notice. Please contact WaterFurnace at 1-888-929-2837 for latest design and specifications. Purchaser's approval of this data set signifies that the equipment is acceptable under the provisions of the job specification. Statements and other information contained herein are not express warranties and do not form the basis of any bargain between the parties, but are merely WaterFurnace's opinion or commendation of its products. The latest version of this document is available at www.waterfurnace.com.